

LAKE WHATCOM WATER AND SEWER DISTRICT



WATER SYSTEM COMPREHENSIVE PLAN

NOVEMBER 2017

Board of Commissioners:

Laura Weide,
Todd Citron, Bruce Ford
John Carter, Curtis Casey

Patrick Sorensen- General Manager

Prepared By:

Wilson Engineering, L.L.C.

805 Dupont Suite 7 Bellingham, Washington 98225
Tel. (360) 733-6100 Fax. (360) 647-9061

INTRODUCTION	1
1. DESCRIPTION OF WATER SYSTEM	2
1.1 Ownership and Management	5
1.2 System Background	6
1.2.1 History of Water System Development and Growth	6
1.2.2 Geography	9
1.2.3 Neighboring/Adjacent Purveyors:	9
1.2.4 Ordinances/Bylaws:	10
1.3 Inventory of Existing Facilities	10
1.4 Related Plans	12
1.5 Existing Service Area Characteristics	13
1.6 Future Service Area	13
1.7 Service Area Agreements	14
1.8 Service Area Policies	14
1.9 Satellite Management Agencies	16
1.10 Conditions of Service (Duty to Serve)	16
1.11 Complaints	17
2. BASIC PLANNING, DATA AND WATER DEMAND	18
2.1 Current Population, Service Connections, Water Use and Equivalent Residential Units	18
2.2 Projected Land Use, Future Population, and Water Demand	20
3. SYSTEM ANALYSIS	29
3.1 System Design Standards	29
3.2 Water Quality Analysis	30
3.3 System Description and Analysis (existing)	30
3.3.1 System Description	30
3.3.2 System Physical Capacities	37
3.3.3 Hydraulic Models and Analysis Results	39
3.3.4 Water Rights Evaluation	46
3.4 Summary of System Deficiencies	47
3.5 Selection and Justification of Proposed Improvement Projects	48

4.1	Water Use Efficiency Plan Development and Implementation	51
4.2	Source of Supply	51
4.5	Interties	53
4.6	Reclaimed Water Opportunities	53
5.	SOURCE WATER PROTECTION	55
5.1.	Wellhead Protection Program	55
5.2.	Watershed Control Program	55
5.3.	System Improvements Analysis, Priority, Alternate Selection	55
6.	OPERATION AND MAINTENANCE PROGRAM	57
6.1.	Water System Management and Personnel	57
6.2	Operator Certification	57
6.3	System Operation and Control	59
6.4	Water Quality Monitoring	60
6.5	Water System Reliability Analysis	60
6.6	Sanitary Survey Findings	63
6.7	Cross-Connection Control Program	64
6.8	Customer Complaint Response Program	64
6.9	Record Keeping and Reporting	64
6.10	O & M Improvements	65
6.11	Safety Procedures	66
7.	DISTRIBUTION FACILITIES DESIGN AND CONSTRUCTION STANDARDS	67
7.1	Project Review Procedures	67
7.2	Policies and Requirements for Outside Parties	67
7.3	Design Standards	67
7.4	Construction Standards	67
7.5	Construction Certification and Follow-up Procedures	68

8.	IMPROVEMENT PROGRAM	69
8.1	Prioritizing Potential Improvements	69
8.1.1	Identification of Potential System Improvements	69
8.1.2	Assessment of Alternatives	70
8.1.3	Selection of Alternatives	70
8.2	Improvement Schedule	70
9.	FINANCIAL PROGRAM	71
9.1	Past and Present Financial Status	71
9.2	Available Revenue Sources	71
9.3	Allocation of Revenue Sources	71
9.4	Program Justification	71
9.5	Assessment of Rates	72
10.	MISCELLANEOUS DOCUMENTS	73
10.1	Supportive Documents	73
10.2	Agreements	2
10.3	Comments on WSP by Others	3
10.4	Water Rights	4
10.5	District Documents Incorporated by Reference	6
	APPENDIX A – SUDDEN VALLEY/GENEVA DETAILED PHYSICAL CAPACITY ANALYSIS	7
	APPENDIX B – WATER USE EFFICIENCY PLAN	9
	APPENDIX C – NORTH SHORE WATER CONSOLIDATION FEASIBILITY STUDY	11
	APPENDIX D – WATER QUANTITY / WATER QUALITY DATA	13
	APPENDIX E – HYDRAULIC ANALYSES	15
	APPENDIX F – FINANCIAL DATA	17
	APPENDIX G – DISTRICT STANDARD DOCUMENT TEMPLATES	19

APPENDIX H – WATER AND SEWER DESIGN STANDARDS AND CONSTRUCTION STANDARDS AND DETAILS 21

APPENDIX I – CAPITAL IMPROVEMENT PLAN – 2017 UPDATE 23

APPENDIX N – STUDY AREA CHARACTERISTICS 25

This Water System Plan was prepared under the direction of the professional engineers whose seals and signatures appear below, each licensed in the State of Washington under Chapter 18.43 RCW.



Introduction

The purpose of this Water System Plan is to assist Lake Whatcom Water and Sewer District (LWWSD, formerly Whatcom County Water District 10) in making the best use of available resources to provide high quality water service and to protect the health of the District's customers.

The Water System Plan will guide the District in its decision-making regarding capital improvements and operations. It will also help the Washington State Department of Health ("DOH") verify that the District's water systems comply with the federal Safe Drinking Water Act and relevant state regulations.

The Water System Plan has been prepared in accordance with the requirements, sequence, and formatting outlined in the Washington Administrative Code WAC 246-290-100. This Plan is an update of the District's 2010 Water System Plan. It is the intent of the Board of Commissioners that, once adopted, this Water System Plan and its appendices will meet current DOH planning standards, and supplant the 2010 Water System Plan. If the current Water System Plan is inadvertently silent on any issue of policy, the Board of Commissioners will separately consider such matters if and when presented by existing or potential water system customers.

1. Description of Water System

Lake Whatcom Water and Sewer District (“District” or “LWWSD”) is located immediately east of and adjacent to the City of Bellingham, and its boundaries encompass much of the Lake Whatcom watershed. The District provides water and sewer services to only a portion of the land contained within its boundaries, the remainder of District land being forested or rural residential in character. The District’s customer base is almost entirely single-family residential, with a very few multi-family, commercial and institutional customers having only a minor impact on the water and sewer systems.

The 2010 Water System Plan divided the District into five Study Areas: Sudden Valley, Geneva, North Shore/City Source, North Shore/Well Source, and South Lake. This Plan will address the District in four Areas with the two previous North Shore study areas combined in to a single North Shore Area. When analyzing existing conditions, the Eagleridge (City source) and Agate Heights (well source) systems will be addressed individually because they are currently separate systems. Future forecasting for the North Shore, however, assumes that the two systems will eventually be consolidated into a single system served by the well source. The Sudden Valley and Geneva Areas remain separate because they are of different residential character and have different water use patterns. The District does not provide, and does not currently plan to provide, water or sewer service to the South Lake Area. Since that represents no change in policy from the 2010 Plan, only the briefest summary of the South Lake Area is included in this report.

Figure 1-1 is a map showing the boundaries of the four District Future Service Areas and the three existing distinct water systems.

Future Service Areas:

- Sudden Valley
- Geneva – Connected to Sudden Valley distribution system
- North Shore – could all be served by District-owned wells in the future
- South Lake – no current District service; no service anticipated in current planning period.

Water systems and sources:

- South Shore (Sudden Valley and Geneva, District treats Lake Whatcom source water)
- North Shore - Eagleridge (bulk water from City of Bellingham (Lake Whatcom source water))
- North Shore - Agate Heights (District-owned wells)
- Johnson Well (2 connections)







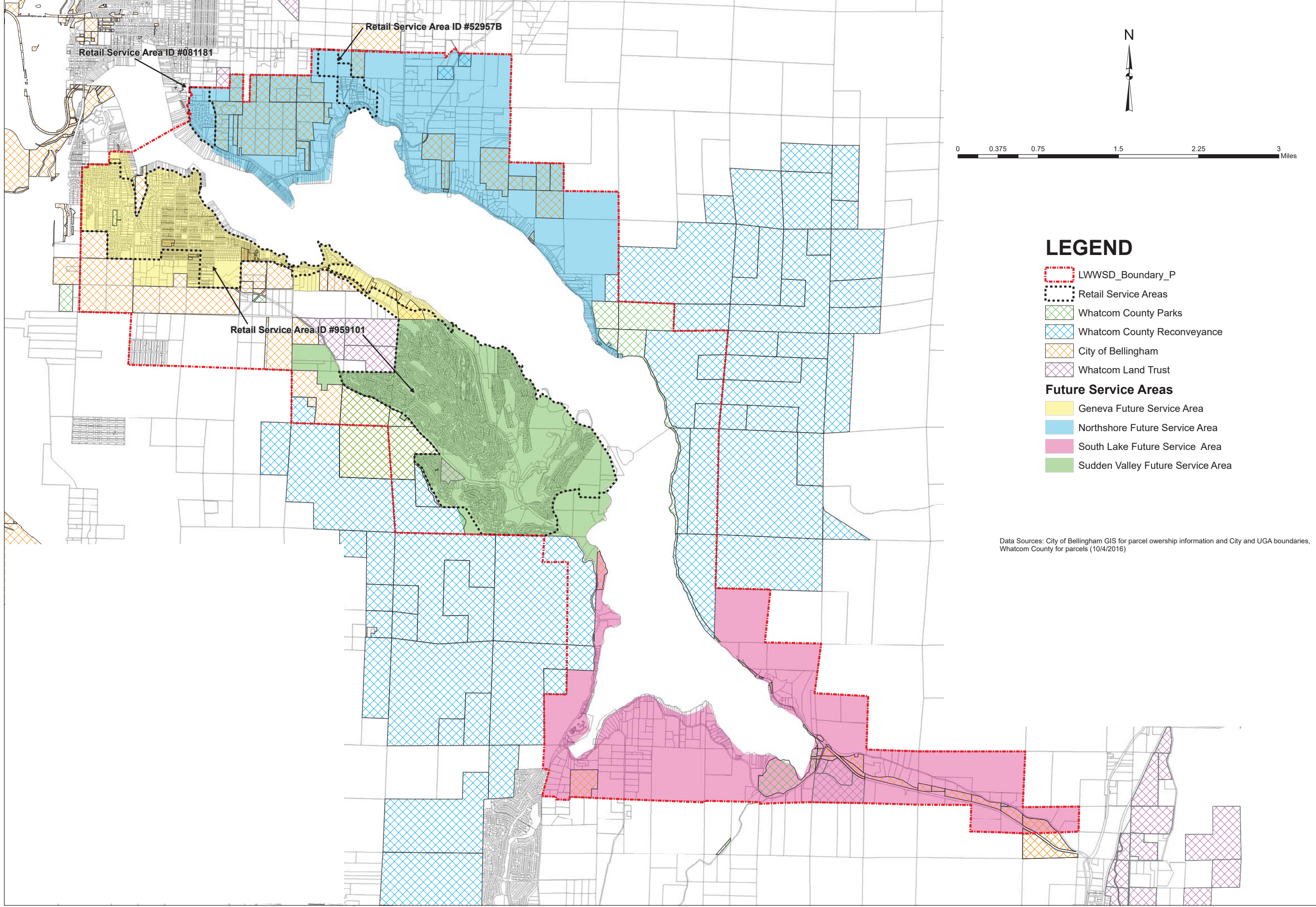



This map also shows the current service area boundaries and water system IDs. The District’s retail service area extends 200 feet beyond the existing service area and is defined by Resolution 757 and the Lake Whatcom Water and Sewer District Administrative Code, Section 3.4 (see Section 10.1 Supportive Documents).

There are areas within the overall District boundary that are not included in any of the Future Service Areas. These areas are zoned rural forestry (RF), commercial forestry (CF), or are owned by the City of Bellingham, Whatcom County, or Whatcom Land Trust and designated as space that will not be developed. Figure 2-1 shows the Whatcom County zoning designations. Given the current climate in the Lake Whatcom Watershed, it is unlikely that these areas will be developed. The District has made no determination not to serve these properties.

The District is proposing minor boundary adjustments in Geneva near its border with the City of Bellingham, and along Academy Road in the North Shore area adjacent to Whatcom County Water District 7. Both of these adjustments are to adjust service areas to eliminate boundary overlaps and acknowledge that the properties are more likely to be served by the adjacent water purveyors.



LEGEND

-  LWWSD_Boundary_P
 -  Retail Service Areas
 -  Whatcom County Parks
 -  Whatcom County Reconveyance
 -  City of Bellingham
 -  Whatcom Land Trust
- Future Service Areas**
-  Geneva Future Service Area
 -  Northshore Future Service Area
 -  South Lake Future Service Area
 -  Sudden Valley Future Service Area

Data Sources: City of Bellingham GIS for parcel ownership information and City and UGA boundaries, Whatcom County for parcels (10/4/2016)

WILSON ENGINEERING, LLC
 805 DUPONT STREET
 BELLINGHAM, WA 98225
 (360)733-6100 FAX(360)647-9061
 www.wilsonengineering.com



Coordinate System:
 State Plane Washington North
 North American Datum 1983

Data Sources:
 City of Bellingham GIS
 Whatcom County Planning & Assessor

LAKE WHATCOM WATER AND SEWER DISTRICT
 WATER SYSTEM PLAN
 FIGURE 1 - 1: BOUNDARY AND SERVICE AREAS

DATE
 SEPT 2017

SCALE
 AS SHOWN

JOB NUMBER
 2016-096

SHEET
 1

OF
 1

1.1 Ownership and Management

The water system name as listed in DOH official records is Lake Whatcom Water and Sewer District. The District's Public Water System ID numbers are:

- 959101 – South Shore Service Area (Geneva to Sudden Valley)
- 081181 – Eagleridge Service Area
- 52957B – Agate Heights Service Area
- 047828 – Johnson Well Service Area (Group B)

The District is a special purpose water and sewer district governed by RCW Chapter 57. A copy of the District's Certification of Registration from the Department of Revenue is included in Chapter 10.1 – Supportive Documents.

The District is governed by an elected, five member Board of Commissioners. The Commissioners determine policy, set rates and charges, and approve the budget. The District employs a full-time General Manager and an operating and administrative staff currently numbering seventeen persons. The General Manager is in charge of daily operations and approves expenditures within the budget. The in-house District Engineer also functions as the Assistant General Manager. The District routinely engages a consultant engineering firm and consultant attorney to advise and aid the Board in its decision-making. The consultant-engineering firm provides analysis, design, plan review, and construction management services to the District on an on-call basis. See Figure 1-2 for the full organizational chart.

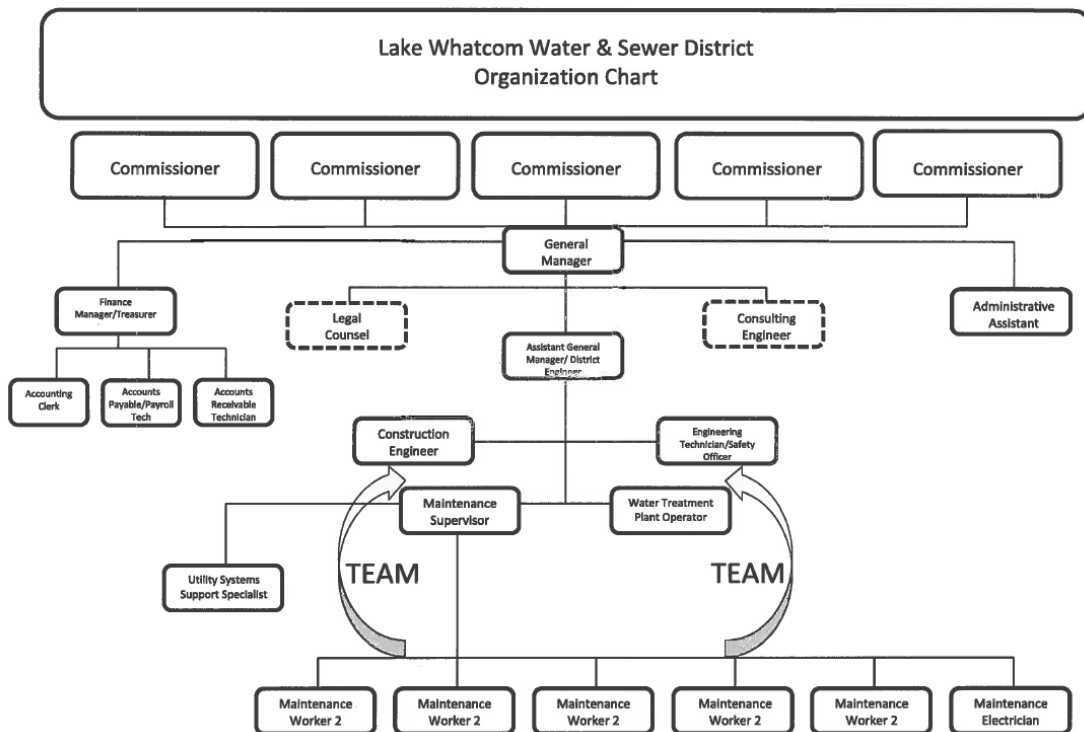

Figure 1-2: Lake Whatcom Water and Sewer District Organizational Chart

Copies of the District's current system Water Facility Inventory forms (WFIs) are included in Chapter 10.1 – Supportive Documents. See these forms for current names, addresses, and telephone numbers of the owners, operators, and emergency contact persons for each system.

1.2 System Background

1.2.1 History of Water System Development and Growth

Lake Whatcom Water and Sewer District was originally formed in 1968 to provide sewer service to the residences around Lake Whatcom that were not already served by the City of Bellingham. Subsequent to formation, the District acquired the water facilities of the Geneva Water Corporation and the Sudden Valley Water Company. From the original purchases, the District has made system extensions and enhancements, and has acquired three water wells on the North Shore of Lake Whatcom.

A. Sudden Valley Area:

In January 1977, the District assumed ownership and operations responsibility of the Sudden Valley Water Company. Sudden Valley was platted as an intended recreational subdivision with approximately 4,400 single-family lots, condominium acreage, golf course, marina, and other resort amenities (the golf course has its own source for irrigation water). The water distribution system for the entire development was constructed within a few years, as opposed to a more typical phased program where homes are built on each lot before the next group of developed lots is made available. The water treatment plant was built in the early 1970's, and was expanded and upgraded in 1992. Growth trends for Sudden Valley include almost complete conversion from part time recreational to full-time residency of retirees and working families with children living at home. The Sudden Valley growth rate was restricted throughout the 1990's by a District-imposed sewer moratorium related to insufficient sewer interceptor capacity. The moratorium is no longer in-place. In 1993 Sudden Valley Community Association undertook an initiative to reduce the density in Sudden Valley by 30% (1,400 lots) through various means including acquisition of lots at tax sales and permanently restricting them from development, allowing lot consolidations, and converting building lots to parks. In 2000 Whatcom County, City of Bellingham and Lake Whatcom Water and Sewer District began participating in these efforts. As of August 2015, 775 of the lots are owned by the Sudden Valley Community Association and placed under restrictive covenant as Common Area, and the total number of lots has been reduced by 1,445. About eighty-five percent of the total remaining estimated building of homes and condos in Sudden Valley has been realized to date.

B. Geneva Area:

In July 1977, Lake Whatcom Water and Sewer District assumed the Geneva Water Corporation, which owned and operated a distribution system and reservoir distributing

City of Bellingham bulk water. Since 1977, the distribution system has been gradually expanded and upgraded by means of numerous utility local improvement districts, developer extensions, and Drinking Water State Revolving Fund loan projects. In 2004, the District installed a water main that connected the Sudden Valley water system to the Geneva water system. This enables the District to supply Geneva with water produced by its water treatment plant in Sudden Valley. The District no longer purchases bulk water from the City of Bellingham, but the connection is still serviceable as an emergency intertie.

The Geneva Area has a mixed history of growth. The State's 1990 Growth Management Act and the 1992 imposition of a sewer capacity moratorium slowed the pace of population growth in the Geneva area. Throughout the 1990-2000's, Whatcom County and the City of Bellingham have been engaged in comprehensive land use planning and/or the legal appeals related thereto in an effort to determine and control maximum potential population densities for the Geneva area. Because most of the Geneva Area is within the Lake Whatcom watershed, efforts have been made to minimize potential impacts of urban development on the water quality of Lake Whatcom while recognizing the existing urban character and development pressures of the area.

The District's Geneva area currently contains several land use categories:

- Urban Growth Area ("UGA"), zoned at three houses per acre ("UR")
- Existing urban character residences located outside of the UGA (Strawberry Point area)
- Rural residential areas outside of the UGA, some with water service, and some anticipated to require water service in the future
- Recreational Open Space (land restricted from development)

The Geneva area also includes the District's approximately 90 sewer-only customers along Lake Whatcom Boulevard, between Geneva and Sudden Valley, and Euclid Avenue. The Lake Whatcom Boulevard customers obtain their potable water from individual wells or direct private withdrawals from Lake Whatcom. The Euclid Avenue customers are served by the Glen Cove Water System which purchased water from the City of Bellingham.

C. North Shore Area - Eagleridge:

There are approximately 107 District water connections in the North Shore Areas while there are over 340 District sewer connections in the same area. The majority of the District's customers in this area are sewer-only customers that are served by individual wells or direct private withdrawals from Lake Whatcom.

The District began operating the Eagleridge Water System in 1989. It currently serves 68 residences from an intertie with the City of Bellingham's water system and a District-owned water booster station.

In 1994, several North Shore lakefront residents attempted to form a water utility local improvement district (ULID) to bring City of Bellingham water to their existing homes.

The petition drive was not successful, so the ULID was not formed. There is sufficient water available under the District's contract with the City, though the contract conditions may make it challenging to serve existing homes if they were not built on lots of record as of June 10, 1988.

The North Shore Consolidation Study (Appendix C) details the potential options to consolidate the Eagleridge, Agate Heights, other Group A and B water systems, and individual wells and direct private surface water withdrawals on the North Shore of Lake Whatcom. The Study assumes that the water source would be the well at Agate Heights, and that the City connection would remain as an emergency back-up supply.

D. North Shore Area - Agate Heights:

The District owns three wells in the same aquifer on the North Shore. They are commonly known as the 6-inch Agate Heights (a.k.a. Giesbrecht) Well, the 10-inch Agate Heights (a.k.a. Giesbrecht) Well, and the Johnson Well.

In 1990, the District entered into an agreement with a group of four developers to construct the 10-inch Agate Heights (a.k.a. Giesbrecht) well east of Agate Bay Road on the North Shore. The intent was to transfer and re-apportion existing District water right permits and applications to better quality wells, so that the new 10-inch well and the existing District "Johnson Well" would comprise the only two points of supply. Department of Ecology (DOE) approved a change in point of withdrawal for a 60 gpm water right permit from the 6-inch Agate Heights (a.k.a. Giesbrecht) Well to the adjacent 10-inch Agate Heights (a.k.a. Giesbrecht) Well based on location criteria. In December, 2002, DOE approved the change in point of withdrawal for a 360 gpm water right permit from the Johnson Well to the 10-inch Agate Heights well. See Section 4.3 for a more detailed discussion of North Shore water rights issues.

The plans for the 10-inch well and a short segment of distribution and transmission mains were approved by Department of Health in the early 1990's with a caveat that manganese treatment and disinfection would have to be provided in later phases before service could be taken from the 10-inch well. This proposed system was identified in the 2001 Water System Plan as the North Shore Central Water System.

Of the four original 1990 developers, Dr. Richard Giesbrecht and Thomas Collins (successor-in-interest to James Doucette) completed a 31-lot subdivision known as Agate Heights (a.k.a. Richalou Estates) in 2001. The subdivision uses water from the 10-inch well, disinfected and treated for manganese. The Department of Health approved the plans for this development and a wellhead protection plan in the spring of 2000. The remaining two original well developers, Trillium and Evergreen View Ventures, have since sold their extensive land holdings on the North Shore to the City of Bellingham, and these properties have been restricted from development.

In 2008, the District added a second water reservoir to serve the Lake Whatcom Residential Treatment Center, located adjacent to Agate Heights. The reservoir provides water for both the treatment center and the upper pressure zone of the Agate Heights subdivision. The existing booster pump was upgraded to a transmission pump to supply the new, higher elevation reservoir. A Pressure Reducing Valve (PRV) vault was also installed to maintain acceptable pressure at the Agate Height subdivision.

Further expansion of the Agate Heights water system within the North Shore Area, beyond the Agate Heights subdivision, is discussed in detail in the North Shore Consolidation Study (Appendix C). As mentioned above, the Study assumes that the water source for the consolidated system would be the well at Agate Heights, and that the City connection at Eagleridge would remain as an emergency back-up supply. The consolidated water system could merge the Eagleridge other Group A and B water systems, and homes with individual wells and direct private surface water withdrawals with the Agate Heights water system.

1.2.2 Geography

Detailed information on the physical characteristics of the Areas is included in Appendix N. Summaries of the geography for each Area are included below.

A. Sudden Valley:

The Sudden Valley water system traverses very steep terrain, with system elevations ranging between 314 and 1,070 feet above sea level. The system has 47 PRVs to maintain appropriate water pressure throughout the system because of the steep terrain. Sudden Valley's water system is interconnected with the Geneva water system. The two systems are currently connected by 1.3 miles of 8-inch water main and one pressure reducing valve. The District's water intake is in the deeper, larger Basin 3 of Lake Whatcom.

B. Geneva:

The Geneva area also includes steep terrain, with elevations in the current service area ranging between 314 and 800 feet above sea level. Geneva currently has two pressure zones served by gravity and a third higher-elevation pressurized zone to serve the south end of the service area. The City of Bellingham bounds this service area on the west.

C. North Shore - Eagleridge:

The Eagleridge system currently has one pressure zone. The City of Bellingham bounds this area on the west.

D. North Shore - Agate Heights:

The Agate Heights (a.k.a. Richalou Estates) water system contains four pressure zones. The original Agate Heights reservoir is at 557 feet above sea level. A second tank was installed at 825 feet to serve the Lake Whatcom Residential and Treatment Center and the highest zone of Agate Heights.

1.2.3 Neighboring/Adjacent Purveyors:

The City of Bellingham is adjacent to the west of the District at Geneva and at Eagleridge. The Glen Cove Water Corporation is located within the Geneva Area and adjacent to Bellingham's City limits. Glen Cove has 21 connections and purchases water from the City of Bellingham. There have been discussions with the Glen Cove Water Association about consolidating with LWWSD and becoming part of the South Shore water system. Adjacent to LWWSD's northern boundary is Whatcom County

Water District #7. Within the North Shore - Agate Heights Area are the following Group A and Group B water systems: Dellesta Park, Agate Bay Trailer Park, Russell Group, Northshore Ridge, Northshore Ridge #2, and North Shore Solar Acres.

There are also several other Group A and Group B systems within the North Shore and South Lake areas that are farther from District infrastructure.

1.2.4 Ordinances/Bylaws:

Resolutions previously adopted by the District Commissioners that affect basic system design have been incorporated into the *Lake Whatcom Water and Sewer District Design and Construction Standards*. The Commissioners may, from time to time, adopt additional Resolutions, which will be incorporated into future revisions of the District Standards. These District standards define the minimum level of service.

The Whatcom County Coordinated Water System Plan Regional Supplement (CWSP) sets forth the design criteria used for fire flow capacities within the District. The CWSP includes a table of minimum fire flow requirements by zoning, or specify that they are to match that of the adjacent municipal corporation, whichever is greater.

1.3 Inventory of Existing Facilities

A. Sudden Valley Area:

The Sudden Valley water system includes:

- 53 miles of water distribution and transmission mains,
- 4 distribution reservoirs (1.0 MG, 0.5 MG, 0.63 MG and 0.15 MG),
- 3 transmission pump installations,
- 47 pressure reducing valve stations, and
- a 2 MGD water treatment plant with adjacent 0.22 MG finished water / chlorine contact reservoir.
- One mile long intertie with Geneva.

The current number of equivalent residential water units (ERUs) in Sudden Valley is 2,685. With approved reduced source criteria (and further decreases in demands, documented in the 2016 Water Use Efficiency Update [Appendix B]), the District's water rights and source supply equipment are sufficient to serve the estimated full build-out of Sudden Valley and Geneva residential connections (see Chapter 10.1 – Supportive Documents for *Sudden Valley Source Criteria Reduction DOH Approval Letter*, April 24, 1996). Estimated full residential build-out for Sudden Valley is 3,267 ERUs based on the number of vacant lots that could be developed (as of August 2015). This build-out estimate does not include ERU allocations for the redevelopment of the closed Sudden Valley Campground, or for the future development of an elementary school. The District's capacity to serve these or other future developments will be evaluated when service is requested.

There is one intertie from the Sudden Valley water system to the Geneva water system. With this intertie the District supplies water to Geneva from its water treatment plant in Sudden Valley.

B. Geneva Area:

The Geneva water system includes:

- 15 miles of water distribution mains,
- 0.5 MG distribution reservoir
- Inactive 0.07 MG reservoir
- One mile long intertie with the Sudden Valley water system
- A transmission pump station (Beecher at Columbus Street)
- 7 pressure reducing valve stations, and
- Two distribution pressure booster stations (LID W-5 and South Geneva at Lake Louise Road).
- An emergency intertie with the City of Bellingham located on Lakeway Drive at Scenic Avenue (currently has a transmission booster pump stations but the District is investigating removing and replacing it with PRV since there is increased pressure on the City side.)

The current number of ERUs in Geneva is 1136. With approved reduced source criteria (and further decreases in demands, documented in the 2016 Water Use Efficiency Update [Appendix B]), the water supply source from Sudden Valley is adequate to supply the estimated full build-out of 1239 connections for Geneva.

A small distribution booster station was added in 1999 at Lookout Ave. / Coronado Ave. in the Geneva Area. The District received a request for water service from 5 single-family homeowners with failing individual wells. The booster station was required since the houses would not have adequate pressure due to their elevation relative to the existing reservoir and their distance from the water main. The home-owners formed LID W-5, plans were approved by DOH, and construction was completed in 1999.

A Developer Extension Agreement project added a booster pump station and approximately 2234 feet of 8-inch HDPE water main to serve existing and future development. The project was constructed in 2010. The booster pump station is located on Lake Louise Road and serves the area in the vicinity of Beecher Ave and 10th / 11th Streets (currently known as Lost Creek Ln.). The future plan is to construct a reservoir at the top of this highest pressure zone and convert the booster pump station to a transmission pump station to feed the future reservoir.

C. North Shore Area - Eagleridge:

Water provided by the District in the Eagleridge water system is supplied from an intertie with the City of Bellingham water system. The City of Bellingham provides

storage for the Eagleridge Water System (for a fee). Eagleridge Water System includes approximately 5000 feet of water distribution mains, and one pressure booster station capable of providing 750 gpm fire flow under peak hourly demand conditions. The system currently serves 68 connections, and build-out for this area would consist of 71 equivalent residential connections. The remaining District customers in the Area are sewer only customers who either draw water directly from Lake Whatcom or own and operate their own wells.

D. North Shore Area - Agate Heights:

The Agate Heights water system includes the 10-inch Agate Heights (a.k.a. Giesbrecht) Well, a water treatment package plant to chlorinate, remove manganese, and pump water to the 79,300 gallon concrete reservoir; a second transmission pump station to fill the 105,700 gallon reservoir; two PRV stations; and over one mile of transmission and distribution mains.

The Johnson Well on Agate Bay Lane currently serves two homes and is not connected to the Agate Heights water system.

1.4 Related Plans

Listed below are the plans that have a bearing on the District planning activities.

Whatcom County Comprehensive Plan

The District's Water System Plan is reflective of the Whatcom County Comprehensive Plan (August 2016). The District requires applicants to assure it that their proposals meet the requirements for land use approvals as set by Whatcom County. The District does not specify any particular land use, density of development, or fire protection standards itself. Rather, it relies upon Whatcom County's GMA-compliant plan and development regulations for those standards and requirements. These considerations and requirements are then incorporated into developer extension agreements.

Provision of water service is a feature of development within both urban and rural areas and is both a rural and urban governmental service according to the Growth Management Act's RCW 36.70A.030 (17) and (18). Where the County's plan and development regulations permit neither urban density development nor an urban level of service, water service may still be available to serve a rural density where this is consistent with County planning and development regulations and it is economically feasible to do so.

This water system plan has been submitted to Whatcom County for a consistency review. The letter and associated checklist is included in Section 10.3.

Whatcom County Coordinated Water System Plan

The District's Water System Plan is consistent with the Whatcom County Coordinated Water System Plan (September 2016). Specific areas of impact are discussed in the appropriate sections of this plan.

Lake Whatcom Watershed Protection Plan

The District's Water System Plan is compatible with the Lake Whatcom Management Program 2015-2019.

City of Bellingham Water System Plan

The District's Water System Plan is consistent with the City of Bellingham Water System Plan (2009 with update in 2013). The City of Bellingham is the wholesale water purveyor for the Eagleridge Water System. The City of Bellingham also provides water storage in its own tanks for the Eagleridge Water System. The City of Bellingham can also provide water to the Geneva area through an emergency intertie.

In accordance with the Whatcom County Coordinated Water System Plan Regional Supplement (CWSP), the District matches the minimum fire flow requirements of the City of Bellingham (the adjacent municipal corporation) for the District's Geneva and North Shore/Eagleridge areas.

Lake Whatcom Water and Sewer District's Sewer Comprehensive Plan

This Water System Plan is consistent with population forecasts of the District's Sewer Comprehensive Plan adopted in May 2014. DOE approval was received on June 6, 2014.

1.5 Existing Service Area Characteristics

Detailed information on the Area characteristics are included in Appendix N. The earlier Figure 1-1 showed the geographic relationship of all District territory subareas. The South Lake area has no District water facilities, and none are proposed within the planning horizon of this plan update.

1.6 Future Service Area

Service can be extended into Future Service Areas shown on Figure 1-1 if all other land use regulations are met. Over the past ten years, distribution system expansions have generally been limited to developer extension agreements or local improvement districts formed by resident petition.

The residences presently served by direct-draw from Lake Whatcom, private wells, or small water systems have been included in the planning forecasts. These residences are located on the north shore from the city limits to the end of North Shore Road, and on the south shore from Strawberry Point in Geneva to Sudden Valley, and along the northern section of Euclid Avenue. The residences on the north shore are discussed in Appendix C, and the residences along the northern section of Euclid Avenue (Glen Cove Water System) have expressed potential interest in consolidating. Grant applications have previously been submitted to investigate the Glen Cove consolidation feasibility, but the District was not one of the successful applicants.

The District considers the South Lake Area a future service area. The District would be open to a citizen petition for a Utility Local Improvement District, or a developer extension, that would bring District service to the area.

The District does not anticipate providing any water service outside its boundaries, and does not anticipate expanding its boundaries in the future. If the District is approached about providing water service outside its boundary, it would determine the feasibility of the expansion and follow the guidelines outlined by the Whatcom County Coordinated Water System Plan. The District may also consider selling water wholesale to nearby water purveyors.

1.7 Service Area Agreements

The District has an agreement with the City of Bellingham for to provide water via an emergency intertie to the South Shore water system. The emergency intertie is located in Geneva at the City limits, and has the capability to fill the Geneva reservoir which can provide water to the Geneva service area.

The City/ District agreement for water service to the North Shore Area - Eagleridge service area is included in Chapter 10.2 – Agreements.

1.8 Service Area Policies

The District's general service area policies are outlined below.

Wholesaling and/or Wheeling Water: The District does not currently wholesale or wheel water to other utilities. The District may consider selling water wholesale to nearby water purveyors. Policies governing wholesaling water would need to be developed prior to the District entering into any wholesale agreements.

Annexation: The District currently has no plans to annex additional territory. The District's Geneva Area is included in the City of Bellingham's Urban Growth Area (UGA); consequently, this area of the District may be subject to annexation some time in the future.

Direct Connection and Satellite/Remote Systems: Resolution 757 defines the District's policy with regard to providing water and/or sewer service within the District borders. The District will generally allow direct connection to its existing facilities if the following conditions are met:

- 1) the development meets the County's Growth Management Act-compliant land use regulations, and
- 2) the development is consistent with the District's own Water and Sewer Comprehensive Plans, and
- 3) the developer agrees to the District's conditions as set forth in a Developer Extension Agreement (which includes the developer assuming financial responsibility for utility extensions).

However, each request is individually considered in light of potential special circumstances that may affect the feasibility of construction and/or operation of new facilities.

Resolution 757 also outlines the procedure for establishing new temporary water systems within the District's borders. As a general rule, the District has declined to own and/or operate Group B water systems or Group A systems that were not constructed

under developer extension agreements. One exception to this is the operation of the North Shore Johnson well, currently serving only two existing residences. The District may consider operating satellite/remote systems on a case-by-case basis for compelling public health reasons, and if doing so will not have a negative financial impact on other District ratepayers. The *Eagleridge Water System* and *Agate Heights Water System (aka Richalou Estates)* are isolated Group A systems created by developers to District standards and now owned and operated by the District.

Design and Performance Standards: The District has adopted minimum design and performance standards equivalent to or better than those in the Whatcom County Coordinated Water System Plan. The District's design and performance standards are defined in *Lake Whatcom Water and Sewer District Design and Construction Standards – September 2017 (Appendix H)*.

Surcharge for Outside Customers: The District currently has no out-of-District customers and no surcharge policy. If and when Outside Customers approach the District for service, the District will address the issue of surcharges.

Formation of Local Improvement Districts Outside Legal Boundaries: The District will evaluate LID's outside the legal boundaries on a case-by-case basis. If the District is approached about providing water service outside its boundary, it would determine the feasibility of the expansion and follow the guidelines outlined by the Whatcom County Coordinated Water System Plan.

Urban Growth Area (UGA): Within an Urban Growth Area, the District may extend water services with minimal permitting, although the District will not generally pursue system extensions unless a developer or group of landowners is willing to pay for the extension up front. If the extension will benefit additional future populations (either infilling on individual lots or future raw land developments), the developer is generally required to size the facilities for those anticipated populations, and is generally allowed to recover a proportionate sum via latecomer agreements with the District. The Geneva Area is the only District area that is part of an UGA (City of Bellingham). The District may consider up-front participation in a developer extension on a case-by case basis if a public health interest would be served by doing so.

Outside of the UGA, service extension requests will be considered on a case-by-case basis and governed by RCW 36.70A.110(4). The facilities will be designed to provide for rural population densities allowed by current zoning, and will be designed in accordance with good engineering practice. According to the Municipal Water Law, Attachment 8, "Rural governmental services' or 'rural services' include those public services and public facilities historically and typically delivered at an intensity usually found in rural areas, and may include domestic water systems, [and] fire and police protection services...Water service must be designated at the level of service designated appropriate by the local land use authority for that area."

Latecomer Agreements: The District provides latecomer agreements for developers whose extensions will benefit additional future development. Agreements are governed by RCW Chapter 57.22.

Oversizing: The District will determine facility over-sizing requirements on a case-by-case basis. Oversizing system components or facilities beyond the capacities needed to serve a particular developer's interests may be necessary to provide comprehensive service to an area without duplication of planning and construction, and to reduce inefficient operations and maintenance. In general, the District will not pay up front for the percentage of oversizing required to support future development of raw land even though the District may require such over-sizing by developers. The District may elect to pay up front for over-sizing necessary to accommodate infilling in areas of existing platted lots. The decisions would be made considering anticipated public benefit and only if the District's up-front contribution was financially feasible.

Cross-Connection Control Program: The District's Cross-Connection Control Program was implemented with the adoption of Resolution No. 227. This Resolution established the legal authority of the District to implement the program, and also adopted the American Water Works Association, Pacific Northwest Section's "*Accepted Procedure and Practice in Cross-Connection Manual*" as the procedural manual for implementing the Cross-Connection Control Program. Resolution No. 227 is included in Chapter 10.1 – Supportive Documents.

Extension: The District has three methods for extending the water system. The first is the Developer Extension Agreement (DEA) – a contractual agreement between a developer and the District to allow the developer to build the extension. This method requires the developer to pay directly for all costs associated with the utility extension.

The second method involves creating a Utility Local Improvement District (ULID). The District pays all costs up front and the beneficiaries of the ULID pay the District back over a period of years.

A third method is a District-initiated project paid for with construction funds on hand, revenue bonds, or public grants and loans. The District may make system upgrades and minor extensions as District-initiated projects, but does not typically extend new lines into previously un-served areas. The payback for borrowed funds is derived from District rates for service and charges for connection to the system. The District has no taxing authority.

Any public system extension must meet the District's minimum design and performance standards, plans must be approved by the District's Engineer, and installation must be inspected by the District or their appointed representative during construction.

1.9 Satellite Management Agencies

The Board of Commissioners reviewed their previous decision not to become a DOH-approved Satellite Management Agency in September 2017. Given that within their borders, the District already has many of the powers associated with being an SMA, the Board affirmed their previous decision and will not seek SMA approval.

1.10 Conditions of Service (Duty to Serve)

The District's Administrative Code defines the conditions under which it will provide water service including having sufficient physical capacity and water rights, and

consistency with local planning and District policies. The District has two documents that are used to procure new water services. The first is the Residential Water Permit Application for single residential requests. The second is the Developer Extension Agreement (DEA) which is used for system extensions by developers. These documents include Purveyor responsibilities, customer responsibilities, current connection fee schedule, consent agreements for inspection, maintenance, and repair activities, cross-connection control requirements, latecomer provisions and project-specific system design requirements in the case of developer extensions. Meter and material specifications are included in the District's design and construction standards. A copy of the Residential Water Permit Application and DEA template are included in Appendix G. The District's design and construction standards are included in Appendix H.

1.11 Complaints

The District's policy and process for dealing with complaints is described in detail in Section 6.8 – Customer Complaint Response Program.

2. Basic Planning, Data and Water Demand

This chapter describes probable land use and population densities as they affect current and anticipated demands placed on the public water system. The annual water demand forecast tables are attached at the end of this section. Historical water use and leakage data are included in Appendix B – Water Use Efficiency Plan. The four major areas are addressed separately below.

2.1 Current Population, Service Connections, Water Use and Equivalent Residential Units

In order to estimate the population of each service area, we multiplied the number of connections (or ERUs) by the average household size for the area according to the 2010 US Census data. The average household size is 2.5 for Sudden Valley, 2.7 for Geneva, and 2.8 for the North Shore.

As part of the District's Water Use Efficiency Plan (WUE), metered data was recorded in each service area. The 2016 WUE report with detailed analysis is included as Appendix B. Demands are based on metered water production and consumption. Average Daily Demand (ADD) and Maximum Daily Demand (MDD) are based on gross production metered records and therefore include any system losses. Distribution System Loss (DSL) is quantified by assessing gross water production against metered consumption.

For all systems, bi-monthly and annual production records for 2012-2014 can be seen in Appendix B, Exhibit 5. Usage by customer class can be seen in Exhibit 1 of Appendix B.

A. Sudden Valley Area:

The Sudden Valley Area had 2,450 connections and 2,687 Equivalent Residential Units (ERUs) as of January 2017. The estimated population is 6,718 (2.5 times the number of ERUs). The majority (88%) of the ERUs come from the "Residential" customer class, 9% of ERUs are of the "Multi Unit" customer class, 3% are of the "Institutional" customer class, and 0.3% are of the "Recreational" customer class.

From the WUE in Appendix B, the highest ADD for 2012-2014 was 131 gallons per day (gpd) per ERU in 2012. This figure assumed 100% full-time occupancy. Based on 2010 Census information, 6.5% of the Sudden Valley area is "occasional use housing", so this would mean that the ADD for full-time residents could be as high as 139.5 gpd/ERU. To remain conservative but more realistic than the 207 gpd/ERU, a value of 150 gpd/ERU will be used for future projections. Because the conservation program is mature and this is a low ADD relative to other water systems, this is the only ADD value used and there is no projection with additional conservation savings.

Based on 2014-2015 data, the highest maximum daily demand (MDD) for Sudden Valley was 175 gpd per ERU, also less than the 335 gpd per ERU approved by Department of Health in 1994. To move closer to actual demands but remain conservative, the value of 250 gpd/ERU will be used for future projections.

Seasonal variation in water demand in Sudden Valley is very small. This can be seen in Appendix B, Exhibit 1 where summer demands are only about 10-20% higher than annual average demands. This is also demonstrated in the low MDD:ADD ratio of 1.34. The low seasonal variation in demand is consistent with the landscaping and forested nature of the community. Exhibit 1 shows that demand from all customer classes increased by a similar amount (roughly 10-20%) in the summer months.

Distribution System Loss (DSL) in Sudden Valley has decreased from 27.6% in 2005-2007 to 12.9% in 2012-2014. See Appendix B for further details and efforts toward minimizing DSL.

B. Geneva Area:

As of January 2017, the Geneva Area had 1,065 service connections and 1,132 ERUs. The estimated population is 3,056 (2.7 times the number of ERU's). The majority (90%) of the ERUs come from the "Residential" customer class, 4% of ERUs are of the "Multi Unit" customer class, and 5% are of the "Institutional" customer class.

Detailed analysis of water use was presented in the WUE Plan (Appendix B). In summary, the highest ADD for 2012-2014 was 152 gpd per ERU (2013). This assumes an estimated 100% full-time occupancy and is less than the 245 gpd per ERU approved in 1997 Source Criteria Reduction Report approved by Department of Health. To remain conservative but more realistic than the 245 gpd/ERU, a value of 175 gpd/ERU will be used for future projections. Because the conservation program is mature and this is a fairly low ADD relative to other water systems, this is the only ADD value used and there is no projection with additional conservation savings.

MDD for Geneva is based on daily readings of the Dutch Harbor intertie meter. The highest MDD for 2014-2015 was 322 gpd per ERU. This is significantly less than the MDD of 500 gpd per ERU approved in 1997. To move closer to actual demands but remain conservative, an MDD of 370 gpd/ERU is used for future projections.

Demand in the Geneva area demonstrates moderate seasonal variability. Exhibit 1 of the Water Use Efficiency Plan shows that summer demands are about 35% higher than annual average demands. The MDD:ADD ratio of about 2 is also in line with this observation. The summer demand increase of 35% is fairly consistent across all three customer classes.

Distribution System Loss (DSL) in Geneva has decreased from 11.0% in 2005-2007 to 9.1% in 2012-2014. See Appendix B for further details and efforts toward minimizing DSL.

C. North Shore Area - Eagleridge:

The District had 68 ERUs on the Eagleridge water system as of January 2017. The estimated population is 197 (2.9 times the number of ERUs). All of the ERUs are from the "Residential" customer class.

Detailed analysis of water use is presented in the WUE (Appendix B). In summary, water use for 2012-2014 shows a maximum ADD of 231 gpd per ERU. This is significantly lower than previous assessments, so to remain conservative but more realistic, an ADD value of 250 gpd/ERU is used for future projections (without

conservation savings). Considering that there is still room for conservation savings since this ADD is still 43% higher than the Geneva ADD, a projected ADD with conservation savings is 210 gpd/ERU.

Based on 2014-2015 data, MDD for Eagleridge future projections is 800 gpd/ERU without conservation savings. With conservation savings, MDD is projected at 600 gpd/ERU.

The Eagleridge water system demonstrates a significant increase in water use in the summer months. Exhibit 1 of the Water Use Efficiency Plan shows that the summer demands of this residential-only system are about 85% higher than the annual average demands. This is consistent with larger lots and summer watering of landscaping. Efforts have been made and are continuing by LWWSD to lower this summer usage (See WUE plan for details).

Distribution System Loss (DSL) in Eagleridge remains minimal at 2.9% in 2012-2014.

D. North Shore Area - Agate Heights:

As of January 2017, the District had 37 service connections and 45 ERUs on the Agate Heights water system and two connections on the Johnson Well. Demand data was not analyzed for the Johnson Well. The estimated Agate Heights population is 131 (2.9 times the number of ERUs). 80% of the ERUs are from the “Residential” customer class, and 20% are from the “Institutional” customer class (Lake Whatcom Residential Treatment Center).

Water use data, included in the WUE report (Appendix B), show the highest ADD from 2012-2014 to be 209 gpd per ERU. To remain conservative but more realistic than the previously used ADD of 300 gpd/ERU, an ADD value of 230 gpd/ERU is used for future projections without conservation savings. Considering that there is still room for conservation savings, a projected ADD with conservation savings is 200 gpd/ERU.

Based on 2014-2015 data, MDD for Agate Heights future projections is 500 gpd/ERU without conservation savings and 420 gpd/ERU with conservation savings.

The Agate Heights water system demand has moderate seasonal variability. Exhibit 1 of the Water Use Efficiency Plan demonstrates a typical increase of about 20% in the summer months compared to annual average demands for both the residential and institutional customer classes.

Distribution System Loss (DSL) in Agate Heights has decreased from a wide range of values in 2005-2007 to 2.8% in 2012-2014. See Appendix B for further details.

2.2 Projected Land Use, Future Population, and Water Demand

Figure 2-1 shows the current Whatcom County zoning including the area within the District’s boundary. A water demand forecast on an annual basis for the ten year planning period (2017 - 2026) and a forecasted twenty year (2036) planning period for each of the District’s water systems is included at the end of Section 2. Included are the forecasted number of ERU’s, total average day demand (ADD) and maximum day demand (MDD), with and without water use efficiency savings assumptions (for the North Shore systems). The Sudden Valley and Geneva areas have conservation

programs that are mature and water use is quite low, so demands with conservation savings represent current demands.

The minimum zoning outside of the Geneva UGA and the Sudden Valley LAMIRD is one lot per five acres (R5A). Whatcom County Code 20.32.252 Rural Residential Overlay allows higher density development with public water, but it only applies to areas designated Rural Neighborhoods in the Whatcom County Comprehensive Plan. ***There are no areas within the District that are designated Rural Neighborhood.*** Therefore, public water will not change the allowable density of any subdivision in the District.

A. Sudden Valley Area

The Sudden Valley Area is a residential area with a golf course and a small strip mall. There are no projected agricultural or industrial water needs. The Sudden Valley Community Association has its own water source for irrigation of the golf course. Future development in Sudden Valley is projected to consist of infill of vacant lots and may include restoring the SVCA Campground or development of private commercial lots near the Village Market.

Water Demand Forecasting: Water demand forecasting for Sudden Valley is summarized at the end of Section 2. The projected growth rate is based on the 2014 LWWS D Comprehensive Sewer Plan, which indicates a projected growth rate of 7 ERU/year for Sudden Valley and Geneva. The current analysis distributed 4 ERU/year to Sudden Valley and 3 ERU/year to Geneva.

The Sudden Valley build-out number of ERUs is based on the following information. In 2015, there were 2667 water ERUs. The Sudden Valley Community Association determined at this time that there were approximately 600 remaining vacant lots after many lots have either been consolidated or purchased by the community association. It is assumed that all future development will be single family residential with one ERU per vacant lot, putting build-out at 3267 ERUs.

The District holds Surface water rights equivalent to 3.4 cfs maximum instantaneous withdrawal, and a total annual withdrawal of 1,800 acre-feet for the combined Sudden Valley and Geneva areas.

B. Geneva Area

The Geneva area is primarily residential but has two schools and a church complex. There are no projected agricultural or industrial water needs.

Water Demand Forecasting: Water demand forecasting for the Geneva Area is summarized at the end of Section 2. The projected growth rate is as indicated above in the Sudden Valley demand forecasting with 3 ERU/year projected growth.

The Geneva build-out number is based primarily on the build-out analysis performed in the 2014 LWWS D Comprehensive Sewer Plan. This determined that build-out for the Geneva area would be 1219 ERUs. This analysis included all areas where water exists or could be extended to except for the area currently served by the South Geneva

booster pump station. This area includes 20 total lots, putting the Geneva area water build-out at 1239 ERUs.

The table showing the combined Sudden Valley / Geneva demand forecasting shows that projected system build-out can easily be met with the existing water rights for both annual total usage and instantaneous withdrawal (which would need to be equal to MDD because equalizing storage accounts for peak demands).

C. North Shore - Eagleridge

The Eagleridge Water System services a residential area. There are no Urban Growth Areas in the District's North Shore area and the zoning previously ranged from RR2 to R5A. Whatcom County has imposed restrictions requiring that all new subdivided properties have a minimum of 5 acres. Therefore, any new development will be rural in nature.

The District planned to serve the 71 Eagleridge development and adjacent residences with the existing Eagleridge Water System. There are also 141 ERUs associated with the failed 1995 ULID W-6 that represent potential connections in this area. Many of these ERUs represent existing residences that currently draw water directly from Lake Whatcom or private wells. See Appendix C, Northshore Consolidation Feasibility Study, for discussion of the possibility of consolidating water systems on the north shore and serving residences between existing systems.

There are no projected non-residential water needs. There are no sources for non-revenue water.

Water Demand Forecasting: Water demand forecasting for the Eagleridge area is summarized at the end of Section 2. The projected growth rate is based on the 2014 LWWSD Comprehensive Sewer Plan, which indicates a projected growth rate of 3 ERU/year for the North Shore area (Eagleridge to Agate Heights). The current analysis distributed 1 ERU/year to Eagleridge and 2 ERU/year to Agate Heights.

Tables are shown both without conservation savings and with projected conservation savings. The maximum number of ERUs that could be served with the existing source is shown for each scenario. These numbers are based on a calculated peak hourly demand, as described in Section 3.3.2 of this Plan. It can be seen that the existing City source limits the number of ERUs that could be served to 85 based on existing demand or 120 ERUs if conservation savings is realized.

A limitation to any future expansion is that the agreement with the City of Bellingham (See Section 10.2, Agreements) stipulates that the district will not supply water for any use other than single-family dwellings on lots of record as of June 10, 1988 without the specific approval of the City of Bellingham. See also discussion below in the Agate Heights section about future expansion/consolidation.

The water usage in Eagleridge is higher per connection than in other District service areas. This may be due in part to larger lot sizes and more landscaping since the highest water use is during the summer. The District has already seen a substantial reduction in MDD and intends to target Eagleridge for further conservation savings. Eagleridge represents less than 2% of the District's connections.

D. North Shore - Agate Heights

The Agate Heights System is rural residential in nature. The existing system was designed to supply 52 ERUs.

Water Demand Forecasting: Water demand forecasting for the Agate Heights Area is summarized at the end of Section 2. The projected growth rate is as indicated above in the North Shore - Eagleridge demand forecasting with 2 ERU/year projected growth. This is not taking potential water system consolidation (as detailed in Appendix C) into account.

Tables are shown both without conservation savings and with projected conservation savings. The tables indicate that with the projected growth, the existing system capacity of 77 ERUs will not be reached in the 10 year planning period but may be reached in the 20 year planning period. The existing system capacity is not limited by water rights but by treatment as explained in Section 3.3.2.

Build-out for the Northshore Area Consolidation is also shown in the tables (See Appendix C for full description and discussion) because this would be served by the Agate Heights water source. As indicated in the table, this demand can be met either with or without conservation savings assuming the whole system will have the same demands as the Agate Heights system. This assumption may not be appropriate and is discussed in more detail in Appendix C.

The Agate Heights System is supplied by a well with a 60 gpm water right permit (G1-22681P), a 360 gpm water right permit (G1-22763P), and a 18 gpm water right certificate (G1-23449). The G1-22763P water right permit was allocated to the 10-inch Geisbrecht (Agate Heights) well through a water right transfer which was completed in 2003. Ownership of the G1-23449 Water Right Certificate was transferred from the Lake Whatcom Residential and Treatment Center to the District when the Center became a District water customer, and the Place of Withdrawal was changed to the 10-inch well.

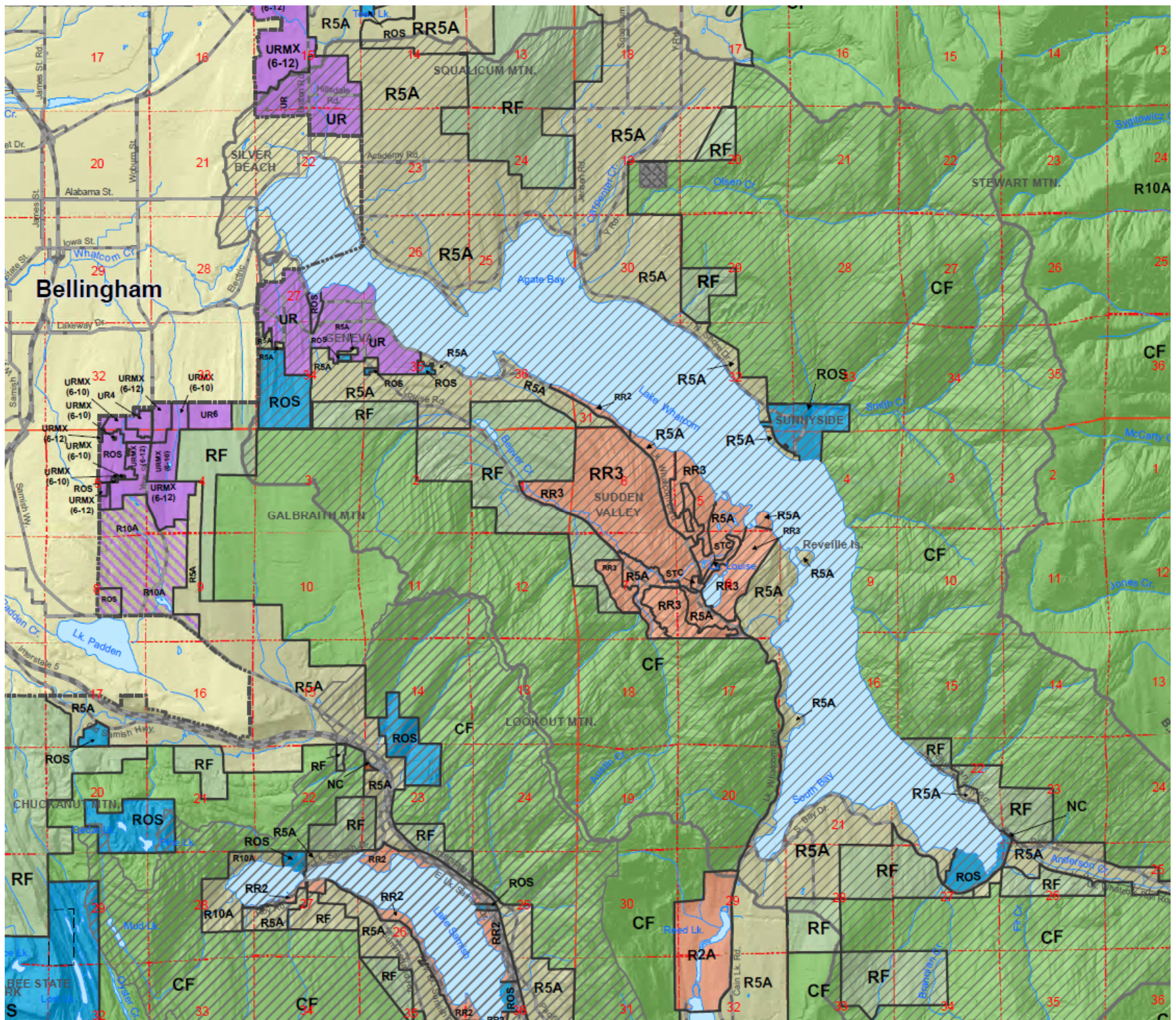

COMPREHENSIVE PLAN DESIGNATIONS

- Incorporated City Limits
- Urban Growth Area
- Urban Growth Area Reserve
- Major/Port Industrial UGA
- Rural
- Rural Neighborhood
- Rural Community
- Rural Tourism
- Rural Business
- Agriculture
- Rural Forestry
- Commercial Forestry

TITLE 20 ZONING DESIGNATIONS

- URBAN RESIDENTIAL**
- URMX Urban Res.-Mixed Use
- URMX10-24 Urban Res.-Mixed Use 10-24 Units/Acre
- URMX6-12 Urban Res.-Mixed Use 6-12 Units/Acre
- URMX6-10 Urban Res.-Mixed Use 6-10 Units/Acre
- URM24 Urban Res.-Medium Density 24 Units/Acre
- URM18 Urban Res.-Medium Density 18 Units/Acre
- URM12 Urban Res.-Medium Density 12 Units/Acre
- URM6 Urban Res.-Medium Density 6 Units/Acre
- UR6 Urban Res.-6 Units/Acre
- UR4 Urban Res.-4 Units/Acre
- UR3 Urban Res.-3 Units/Acre

- RURAL RESIDENTIAL**
- RR3 Rural Res.-3 Units/Acre
- RR2 Rural Res.-2 Units/Acre
- RR1 Rural Res.-1 Unit/Acre
- RR5A Rural Res.-1 Unit/5 Acres
- RR10A Rural Res.-1 Unit/10 Acres

- RURAL RESIDENTIAL**
- RR1 Rural Residential Island
- TZ Transitional-R5A/RR1
- RURAL**
- R2A Rural-1Unit/2 Acres
- R5A Rural-1 Unit/5 Acres
- R10A Rural-1 Unit/10 Acres

- RESOURCES**
- AG Agriculture
- CF Commercial Forestry
- RF Rural Forestry
- MRL Mineral Resource Lands (Overlay Zone)

- COMMERCIAL**
- RGC Rural General Comm.
- GC General Commercial
- TC Tourist Commercial
- NC Neighborhood Commercial
- STC Small Town Commercial
- RC Resort Commercial

- INDUSTRIAL**
- HI Heavy Impact Industrial
- LII Light Impact Industrial
- GM General Manufacturing
- GI Gateway Industrial
- RIM Rural Ind. Manuf.
- AO Airport Operations

- OTHER**
- ROS Recreation Open Space
- EI Eliza Island

R5A*, RR5A* - Rural Residential Density Overlay - Title 20.20.32.232

Transferrable Development Rights (TDRs)
TDR Receiving Areas - All URMX Zones except Bennett Dr.

TDR Sending Areas - Lake Whatcom Watershed (same boundary as Lake Whatcom portion of Water Resource Protection Overlay Zone) excluding Sudden Valley

Legend



USE OF WHATCOM COUNTY'S GIS DATA IMPLIES THE USER'S AGREEMENT WITH THE FOLLOWING STATEMENT:
Whatcom County disclaims any warranty of merchantability or warranty of fitness of this map for any particular purpose, other express or implied. The representations or warranty made concerning the accuracy, currency, completeness or quality of data depicted on this map. Any user of this map assumes all responsibility for use thereof, and further agrees to hold Whatcom County harmless from and against any damages, losses, or liabilities arising from any use of this map.

Figure 2-1: Whatcom County Zoning

SECTION 2

Water Demand Forecasting

SUDDEN VALLEY WATER SYSTEM

Water Demand Forecasting		With Conservation Savings (existing demand, conservation program is mature)	
	ERUs**	Total Average Volume -GPD (based on ADD= 150 gpd/ERU)	Maximum Daily Volume-GPD (based on MDD*= 250 gpd/ERU)
2016	2676	401,400	669,000
2017	2687	403,050	671,750
2018	2691	403,650	672,750
2019	2695	404,250	673,750
2020	2699	404,850	674,750
2021	2703	405,450	675,750
2022	2707	406,050	676,750
2023	2711	406,650	677,750
2024	2715	407,250	678,750
2025	2719	407,850	679,750
2026	2723	408,450	680,750
2036	2763	414,450	690,750
Full build-out	3267	490,050	816,750
Water Rights – Annual / Instant. (shared with Geneva)		Annual (Daily Avg) = 1,607,178 GPD Instantaneous = 2,197,472 GPD	

GENEVA WATER SYSTEM

Water Demand Forecasting		With Conservation Savings (existing demand, conservation program is mature)	
	ERUs**	Total Average Volume -GPD (based on ADD= 175 gpd/ERU)	Maximum Daily Volume-GPD (based on MDD*= 370 gpd/ERU)
2016	1136	198,800	420,320
2017	1132	198,100	418,840
2018	1135	198,625	419,950
2019	1138	199,150	421,060
2020	1141	199,675	422,170
2021	1144	200,200	423,280
2022	1147	200,725	424,390
2023	1150	201,250	425,500
2024	1153	201,775	426,610
2025	1156	202,300	427,720
2026	1159	202,825	428,830
2036	1189	208,075	439,930
Full build-out	1239	216,825	458,430
Water Rights – Annual / Instant. (shared with Sudden Valley)		Annual (Daily Avg) = 1,607,178 GPD Instantaneous = 2,197,472 GPD	

* ADD and MDD values are based on source data which includes distribution system leakage.

** ERU growth projections match 2014 LWWS D Comprehensive Sewer Plan

7 ERU/year for Sudden Valley and Geneva

SECTION 2

Water Demand Forecasting

COMBINED SUDDEN VALLEY/GENEVA WATER SYSTEMS

Water Demand Forecasting	With Conservation Savings (existing demand, conservation program is mature)		
	ERUs**	Total Average Volume (GPD)	Maximum Daily Volume* (GPD)
2016	3812	600,200	1,089,320
2017	3819	601,150	1,090,590
2018	3826	602,275	1,092,700
2019	3833	603,400	1,094,810
2020	3840	604,525	1,096,920
2021	3847	605,650	1,099,030
2022	3854	606,775	1,101,140
2023	3861	607,900	1,103,250
2024	3868	609,025	1,105,360
2025	3875	610,150	1,107,470
2026	3882	611,275	1,109,580
2036	3952	622,525	1,130,680
Sudden Valley full build-out	3267	490,050	816,750
Geneva full build-out	1239	216,825	458,430
Combined full build-out	4506	706,875	1,275,180
Water Rights – Annual / Instant.		Annual (Daily Avg) = 1,607,178 GPD Instantaneous = 2,197,472 GPD	

* ADD and MDD values are based on source data which includes distribution system leakage.

** ERU growth projections match 2014 LWWSD Comprehensive Sewer Plan

7 ERU/year for Sudden Valley and Geneva

SECTION 2

Water Demand Forecasting

NORTH SHORE /EAGLERIDGE WATER SYSTEM

Water Demand Forecasting	ERUs	Without Conservation Savings (Existing)	
		Total Average Volume -GPD (based on ADD= 250 gpd/ERU)	Maximum Daily Volume-GPD (based on MDD*= 800 gpd/ERU)
2016	68	17,000	54,400
2017	68	17,000	54,400
2018	69	17,250	55,200
2019	70	17,500	56,000
2020	71	17,750	56,800
2021	72	18,000	57,600
2022	73	18,250	58,400
2023	74	18,500	59,200
2024	75	18,750	60,000
2025	76	19,000	60,800
2026	77	19,250	61,600
2036	87	21,750	69,600
Maximum Number of ERUs**	85	21,250	68,000
City Connection – 150 gpm**	85	216,000 gpd	

NORTH SHORE /EAGLERIDGE WATER SYSTEM

Water Demand Forecasting	ERUs	With Projected Conservation Savings	
		Total Average Volume -GPD (based on ADD= 210 gpd/ERU)	Maximum Daily Volume-GPD (based on MDD*= 600 gpd/ERU)
2016	68	14,280	40,800
2017	68	14,280	40,800
2018	69	14,490	41,400
2019	70	14,700	42,000
2020	71	14,910	42,600
2021	72	15,120	43,200
2022	73	15,330	43,800
2023	74	15,540	44,400
2024	75	15,750	45,000
2025	76	15,960	45,600
2026	77	16,170	46,200
2036	87	18,270	52,200
Maximum Number of ERUs**	120	25,200	72,000
City Connection – 150 gpm**	120	216,000 gpd	

* ADD and MDD values are based on source data which includes distribution system leakage.

** Based on the City Connection limit of 150 gpm and Peak Hourly Demand, as calculated by Equation 5-1 from the DOH Water System Design Manual

SECTION 2

Water Demand Forecasting

NORTH SHORE WELL SYSTEM

Water Demand Forecasting	ERUs	Without Conservation Savings (Existing)	
		Total Average Volume -GPD (based on ADD= 230 gpd/ERU)	Maximum Daily Volume-GPD (based on MDD*= 500 gpd/ERU)
2016	45	10,350	22,500
2017	45	10,350	22,500
2018	47	10,810	23,500
2019	49	11,270	24,500
2020	51	11,730	25,500
2021	53	12,190	26,500
2022	55	12,650	27,500
2023	57	13,110	28,500
2024	59	13,570	29,500
2025	61	14,030	30,500
2026	63	14,490	31,500
2036	83	19,090	41,500
Build-out of existing system**	77	17,710	38,500
Build-out of Northshore Area Consolidation	530	121,900	265,000
Water Rights – Annual / Instant.		Annual (Daily Avg) = 452,500 GPD (506.9 acre-ft/yr) Instantaneous = 630,720 GPD (438 GPM)	

NORTH SHORE WELL SYSTEM

Water Demand Forecasting	ERUs	With Projected Conservation Savings	
		Total Average Volume -GPD (based on ADD= 200 gpd/ERU)	Maximum Daily Volume-GPD (based on MDD*= 420 gpd/ERU)
2016	45	9,000	18,900
2017	45	9,000	18,900
2018	47	9,400	19,740
2019	49	9,800	20,580
2020	51	10,200	21,420
2021	53	10,600	22,260
2022	55	11,000	23,100
2023	57	11,400	23,940
2024	59	11,800	24,780
2025	61	12,200	25,620
2026	63	12,600	26,460
2036	83	16,600	34,860
Build-out of existing system**	77	15,400	32,340
Build-out of Northshore Area Consolidation	530	106,000	222,600
Water Rights – Annual / Instant.		Annual (Daily Avg) = 452,500 GPD (506.9 acre-ft/yr) Instantaneous = 630,720 GPD (438 GPM)	

* ADD and MDD values are based on source data which includes distribution system leakage.

** Based on the existing treatment capacity

3. System Analysis

3.1 System Design Standards

The District has adopted the Design Standards set forth in WAC 246-290-200 through 246-290-250 and the Whatcom County Coordinated Water System Plan (CWSP) (September 2016). The *Standards Incorporated by Reference* into the CWSP are also adopted by the District and incorporated into this Plan. The District’s standards can be found in Appendix H.

LWWSD adopts and establishes the following standards for construction and operation of its Group A water systems.

PARAMETER	STANDARD		
	Sudden Valley	Geneva	North Shore
Water Quality	In accordance with the federal Safe Drinking Water Act (SDWA), DOH criteria specified in WAC 246-290, and Whatcom County CWSP, all as amended from time to time.		
Average Daily Demands	150 gpd/ERU	175 gpd/ERU	250 gpd/ERU (Eagleridge) 230 gpd/ERU (Agate Heights)
Maximum Daily Demands	250 gpd/ERU	370 gpd/ERU	800 gpd/ERU (Eagleridge) 500 gpd/ERU (Agate Heights)
Peak Hour Demand	Pressure zone – dependent	Pressure zone - dependent	Pressure zone - dependent
Storage Requirements: Standby	300 gallons/ERU	350 gallons/ERU	500 gallons/ERU (Eagleridge) 460 gallons/ERU (Agate Heights)
Fire Flow Rate and Duration	Res.: 500 gpm/60 min. Commercial/Condos: 750 gpm/60 minutes	750 gpm/60 minutes	Eagleridge and Agate Heights: 500 gpm/60 minutes
Minimum System Pressure	In accordance with WAC 246-290-230 and the Whatcom County CWSP		
Minimum Pipe Sizes	See <i>LWWSD Design and Construction Standards – 2017</i> .		
Telemetry Systems	PLC, PC-based, <i>Intellution</i> , open architecture SCADA		
Backup Power Requirements	Reviewed on a case-by-case basis.		
Valve Spacing	Every 500 feet.		
Hydrant Spacing	Every 600 feet.		
Other System Policies that Affect Performance and Design	See <i>LWWSD Design and Construction Standards – 2017</i> .		

3.2 Water Quality Analysis

A. Sudden Valley:

Lake Whatcom is the raw source water for the Sudden Valley Water Treatment Plant. Source water quality analysis is performed by the District in accordance with State standards and the District's Comprehensive Monitoring Plan (see Chapter 6). Source water quality has remained consistently excellent with temporary seasonal turbidity changes (due to Lake turning impacts). The District submits monthly Water Treatment Plant reports to the Department of Health.

Distribution system water quality is monitored in accordance with the Comprehensive Monitoring Plan. Test results for the past 7 years have yielded acceptable results with three positive coliform tests (for the combined Sudden Valley and Geneva system). The sample locations were re-tested with negative results.

See Section 6.8 for a discussion of water quality complaints.

B. Geneva:

Source is the same as Sudden Valley, see above.

C. North Shore - Eagleridge:

The City of Bellingham is the source water for the Eagleridge Water System. Source water quality analysis is performed by the City. Distribution system water quality is monitored in accordance with the Comprehensive Monitoring Plan. Test results for the past 7 years have yielded acceptable results, with zero positive coliform results.

See Section 6.8 for a discussion of water quality complaints.

D. North Shore - Agate Heights:

The Agate Heights water system was brought on line in May 2001 as a Group A system with manganese removal and disinfection. Distribution system water quality is monitored in accordance with the Comprehensive Monitoring Plan. Test results for the past 17 years have yielded zero positive coliform results. The source water quality for the 10-inch North Shore well was contained in the original engineering project report for *Richalou Estates*.

3.3 System Description and Analysis (existing)

3.3.1 System Description

A. Sudden Valley Area:

Source – The raw water source is Lake Whatcom. The required water rights self-evaluation is included in Chapter 4. Maximum instantaneous withdrawal rate is 3.4 cubic feet per second (1,526 gpm) and annual withdrawal volume is 1,800 acre-feet. The source quality is excellent with only occasional spikes in turbidity due to seasonal lake effect or winter storms that may carry sediment into the lake. The intake facilities were inspected in 1998 and found to be in good condition. The raw water pumps were replaced in 1992, and the motors were replaced/rebuilt in 2012. Capacity of the transmission main is sufficient.

Treatment – The Sudden Valley Treatment Plant was upgraded in 1992 to increase raw water and transmission pumping capacities to match the capacity of the 2-MGD filtration system. Additional objectives included increasing the reliability of the plant and complying with the EPA's Surface Water Treatment Rules (SWTR). The plant is capable of producing 2 MGD of treated, disinfected water and delivering it to the distribution system, with 100% backup capacity of all pumping systems, and natural gas standby power capable of operating the plant at full capacity. The treatment plant is a direct filtration treatment plant with disinfection provided by gas chlorine.

Type of Pump	System Capacities	Current Operations
Raw Water	2 - 1400gpm each	700 gpm
Transfer	2 - 1400 gpm each	700 gpm
Transmission – Div. 7	2- 840 gpm @ 390 feet TDH each	840 gpm
Transmission – Div. 22	2- 700 gpm @ 608 feet TDH each	725 gpm

A baffled, welded steel, 0.22 MG above grade storage tank was constructed at the plant site in 1992 to provide disinfection contact time to meet SWTR requirements. Transfer pumps move the water from the clearwell to the contact time storage tank. The transmission pumps then pump water from the storage tank to the portions of the distribution systems that feed the Division 7 and Division 22 reservoirs.

Based on the SWTR Guidance Manual and confirmed by the Department of Health's sanitary survey of operations, the Sudden Valley Water Treatment Plant (WTP) is a "well-operated direct filtration plant." The filtration step of "well-operated direct filtration plants" is assumed to achieve 2-log removal of Giardia cysts and 1-log removal of viruses. SWTR requires an overall 3-log removal of Giardia cysts and 4-log removal of viruses. Therefore the disinfection step must deactivate 1-log of Giardia cysts and 3-log of viruses. The SWTR Guidance Manual contains CT Tables which list Giardia cyst and virus deactivation levels as a function of disinfectant concentration and contact time. CT is the product of the disinfectant concentration and the effective contact time.

The Long Term 2 Enhanced Surface Water Treatment Rule (LT2ESWTR) requires source water monitoring to determine Cryptosporidium risk. As a system serving less than 10,000 people, the south shore water system has monitored source water E. coli to comply with the rule. Monitoring has always shown a concentration less than the trigger level of 10 E. coli / 100 mL. Therefore, additional treatment for Cryptosporidium is not required.

The disinfection contact time provided by the tank was investigated in detail in a study by the Department of Health in 2016. This study concluded that the baffling efficiency (T_{10}/T) used to calculate contact time in the tank should be adjusted from 0.7 to 0.3. This change and its subsequent requirement to increase chlorine concentration to meet the required CT has been implemented.

The required CT for chlorine at 5°C (the plant's minimum water temperature, a conservative assumption), a pH of 7.0 (the plant's minimum finished water pH, a conservative assumption), and a chlorine concentration of 1.2 mg/L (highest typical dose is 1.1 mg/L, so this is a conservative assumption) is listed below:

Table 3.3-2 REQUIRED CT				
Disinfectant	1-log Removal Giardia Cysts	pH	3-log Removal Viruses	pH
Cl ₂	51	7.0	6	6-9

The minimum capacity required to provide a CT of 51 based on a flow rate of 1,400 gpm (2 MGD), a Cl₂ concentration of 1.2 mg/l, and a short circuiting or hydraulic efficiency factor of 0.3 is 198,000 gallons. The existing 220,000 gallon tank is capable of providing this if it is operated such that the level in the tank is maintained above 21.1 ft to maintain the 198,000 gallons. It may be challenging to operate the system and balance flows in to and out of the CT tank to maintain a level of 21.1 ft without reaching the overflow at a level of approximately 23.3 ft, but it is possible.

The current operation is such that the flow rate through the filters is 700 gpm and that flow rate goes in to the clearwell. From the clearwell, it is pumped by the transfer pump to the CT reservoir. The transfer pump is a constant rate pump that pumps at 1400 gpm and operates based on an on and off level in the clearwell. The flow rate out of the CT reservoir is dictated by the transmission pump flow rates (either 725 gpm to Div 22 or 840 to Div 7). The greater of the flow in to or out of the CT reservoir (averaged over one hour) dictates contact time. The current average flow rate is 700 gpm based on the operating flow rate of the plant.

But when the plant is operated at 1400 gpm, the transfer pump would operate at 1400 gpm constantly and would not need to be cycled on and off. The transmission pumps to both Div 22 and Div 7 could be operated (and throttled to 700 gpm each) so that flow in and flow out of the CT reservoir were both 1400 gpm. As long as the above parameters were met (minimum level of 21.1 ft and chlorine concentration of 1.2 mg/L), the required CT would be provided.

The plant is typically operated at half its capacity, approximately 700 gpm. At this flow rate, 99,000 gallons is required. Options could be investigated to utilize additional water system components for the calculation of contact time. Because the plant pre-chlorinates with a low chlorine dose, additional CT could be calculated for the flocculation basin and filters. There is some pipe between the outlet of the CT tank and the first customer. There is a substantial length of pipe between the outlet of the CT tank and the

first customer on the line going toward the Division 22 reservoir (approximately 23 minutes of hydraulic residence time). But there is much less pipe between the outlet of the CT tank and the first customer on the line going toward the Division 7 reservoir (approximately 2.5 minutes of hydraulic residence time). Because of the limited additional benefit of the 2.5 minutes of time toward the CT calculation, it would not be worth it to add monitoring stations at each of the two entry to distribution points.

The 2-MGD treatment train includes the following functions:

- Screened raw water pumping
- Addition of alum as flocculating agent
- Coagulation and flocculation
- Pre-chlorination
- Filtration
- Automated filter backwash (to equalization tank, then sanitary sewer)
- Filter to Waste (to sanitary sewer)
- Chlorine disinfection in baffled contact reservoir

A more detailed description of the treatment plant process is included in the *Sudden Valley Water Treatment Plant Operations Plan* (See Appendix J, revised 2017).

Storage – The Sudden Valley Area includes three older and one new distribution reservoirs and a finished water reservoir for disinfectant contact time at the treatment plant. A second reservoir has recently been constructed at Division 22 to improve storage capacity and operational efficiency. The new Division 22 reservoir is operated in parallel with the existing 0.50 MG Division 22 reservoir.

Reservoir Location	Capacity(MG)	Material	Approx. Base Elev. (ft, NAVD88)	Approx. Top Elev. (ft NAVD88)	Diam. (ft)
SV Div. 7	1.00	welded steel	670.45	705.45	70
SV Div. 22	0.50	welded steel	804.65	839.65	50
SV Div. 22 New	0.63	welded steel	805	840	56
SV Div. 30	0.15	welded steel	1027.98	1067.98	25
SUBTOTAL	2.28				
Water Plant CT	0.22	welded steel	334.29	358.29	40
TOTAL VOL.	2.5				

The three existing distribution reservoirs serve somewhat overlapping geographic areas of Sudden Valley. The Division 7 and Division 22 reservoirs are fed by transfer pumps directly from the CT reservoir at the water treatment plant. The Division 30

transmission pump station is located in the Division 7 reservoir service area; the station pumps water from the 1.0 MG Division 7 reservoir to the Division 30 reservoir. The Division 30 reservoir, the highest reservoir, in turn can supply part of the area also served by the Division 22 reservoir, depending on the settings of the pressure reducing valves.

With the installation of the Sudden Valley-Geneva water intertie in 2003, the Division 22 reservoir is also serving part of Geneva, and the Division 30 reservoir is covering a larger area, to utilize more of the 1.0 MG Division 7 reservoir capacity. This was described in detail in the Sudden Valley- Geneva Water System Intertie Project Report (2002). The second reservoir at Division 22 will allow the system to operate more efficiently. Sufficient storage enables the larger, intended area to be fed from Division 22 instead of being fed from Div. 30 as is the current operation. The Pre-Design Report for this addition contains detailed analysis.

Distribution System – The Sudden Valley water system was completed in 1974. The water system includes approximately 42 miles of water distribution mains of the types and sizes shown in the table below. Some distribution mains that were originally installed have since been decommissioned due to restrictions in development.

The system does suffer isolated main breaks that are difficult to find due to the hilly terrain in Sudden Valley. Much of the water main pipe material is cast iron, and several leaks have been due to full circle pipe breaks. The cause of at least one main break appeared to be point loading of the pipe against rock, indicating improper or shifted bedding.

The 47 PRV stations are maintained annually, and are included in an on-going repair/replacement program. Replacing aging customer services is also part of the on-going maintenance program. Radio-read retrofit for all the residential service meters was completed in 2007. Retrofitting the radio-read meters for commercial services was completed around 2010.

Throughout the Sudden Valley water system, only minor distribution system deficiencies were identified. See Section 3.3.3, Hydraulic Models for a discussion of the distribution system and potential deficiencies.

TABLE 3.3-4 SUDDEN VALLEY AREA PIPE MATERIAL QUANTITIES		
Material	Range (Inches)	Length (Ft)
PVC	2	2,000
Ductile Iron/Cast Iron	3-12	219,196

B. Geneva Area:

Source – An intertie between the Sudden Valley and Geneva has been installed and is now the primary supply source to Geneva. The old City of Bellingham intertie remains in-place as an emergency backup. The City recently increased its operating pressure in the area by intertie such that the intertie can now be changed from a pump

station to a PRV because the City pressure is higher than the operating pressure in Geneva. The water intakes for the City’s surface water treatment plant and the District’s Sudden Valley surface water treatment plant are approximately four miles apart.

Treatment – Sudden Valley source; See Sudden Valley section for treatment description. See City of Bellingham Water System Plan for treatment description for water fed through emergency intertie.

Storage – The Geneva Area has a single, welded steel, 0.5-MG reservoir located behind the District office at 1010 Lakeview Street. It has a base elevation of approximately 661.12 ft (NAVD88), a diameter of 52 ft, and a nominal height of 32 ft. As discussed above, the Division 22 reservoir is also serving part of Geneva. This eliminated the need for additional reservoir capacity in Geneva. See Section 3.3.2 for a discussion of storage capacities.

Distribution System – The distribution system in the Geneva Area is a mix of old and new water mains. With the completion of projects in 2000 to replace all old 2” galvanized waterlines, and completion of the service meter replacement program, distribution system losses in Geneva have been reduced.

The remainder of all known asbestos cement (AC) water main in Geneva was replaced in the summer of 2015 (approximately 12,000 ft of pipe). Now most of the water main pipe material is ductile iron except a couple of sections of HDPE water main. The PRV stations are all are maintained on an annual basis.

There was one section of the distribution that had higher than desirable water pressure (looped area from Lowell Ave. to Oriental Ave.). Pressure Reducing Valve (PRV) stations were installed on Lowell Ave. and Oriental Ave. in 2012 to remedy this issue.

TABLE 3.3-5 GENEVA AREA PIPE MATERIAL QUANTITIES		
Material	Range (Inches)	Length (Ft)
Cast Iron	6	291
Ductile Iron	4-12	78,891
HDPE	8	3334

C. North Shore Area - Eagleridge:

Source – The City of Bellingham provides the source water for the Eagleridge Water System.

Treatment – The City of Bellingham provides treatment.

Storage – The City of Bellingham provides standby storage for the existing Eagleridge Water System.

Distribution System – The Eagleridge Water System was completed in 1989. The system has a booster station (three domestic flow pumps, two fire suppression pumps) and approximately 5,000 feet of ductile iron pipe. See Section 3.3.3 Hydraulic Models

for a discussion about potentially eliminating the booster station domestic pumps because of increased pressure from the City source.

D. North Shore Area - Agate Heights:

Department of Health approved the project report, wellhead protection plan, and construction plans for the Agate Heights water system in May 2000. The system was completed and operational in May 2001. The system was expanded in 2008 to connect the Lake Whatcom Residential and Treatment Center.

Source – The 10-inch Agate Heights (a.k.a. Giesbrecht) well was completed in 1990-91 in the Squalicum aquifer. It has a capacity of 484 gpm, and three water rights for a total of 438 gpm instantaneous withdrawal and 506.9 acre-feet annually.

Treatment – The well water quality requires removal of manganese as a secondary contaminant. Manganese removal and a chlorine residual are provided by oxidation of the manganese with chlorine followed by filtration. A package filtration plant was installed to provide this treatment. See Agate Heights Operations and Maintenance Manual (incorporated by reference, updated in 2017) for additional details about this treatment system.

Storage – A 79,300 gallon reservoir was installed in 2000 to supply the Richalou Estates Development (now Agate Heights). This reservoir is made of concrete with a 30 ft diameter, 15 ft height, and base elevation 555.29 ft (NAVD88). A 105,700 gallon reservoir was installed in 2008 to supply the Lake Whatcom Residential Treatment Center and Agate Heights (formerly Richalou Estates). This reservoir is made of concrete with a 30 ft diameter, 20 ft height, and base elevation 824.04 ft (NAVD88). The system has four pressure zones. The 105,700 gallon reservoir directly feeds the treatment center, and it also feeds the zone including houses on Opal Terrace through a PRV. The 79,300 gallon reservoir is used as intermediate storage for the upper system and serves the lower connections, some of which are served by the hydraulic grade of the 79,300 gallon reservoir, and some of which are fed through a PRV in the lowest zone. See Section 3.3.2 for a discussion of the capacities of the storage tanks.

Distribution System – The transmission and distribution system consists of approximately 7,000 LF of 4- to 8- inch ductile iron mains. The pumps that pressurize the package treatment plant also pump the treated, disinfected water to the 79,300 gallon reservoir. With the 2008 improvements, the pressure booster system serving the highest pressure zone was converted to a transmission pump system to pump water from the 79,300 gallon reservoir to the 105,700 gallon reservoir. There are two PRVs to separate the pressure zones. See Section 3.3.3 for further discussion of the distribution system.

3.3.2 System Physical Capacities

A. Sudden Valley: and

B. Geneva:

A detailed physical capacity analysis for Sudden Valley and Geneva can be found in Appendix A. The detailed analysis is summarized below. The recent addition of the new Division 22 reservoir is incorporated in to the analysis.

Appendix A demonstrates that the component that limits the physical capacity of the existing water system is storage. Water rights, pump capacity, treatment capacity, and distribution capacity are less limiting to physical capacity than storage. Physical capacity to serve Equivalent Residential Units (ERUs) is shown below.

	Sudden Valley	Geneva
Capacity based on most limiting factor [storage] (ERUs)	4600	1738

The distribution of these ERUs is constrained by the geographical distribution of the service areas of each reservoir, as shown in Table A-1 of Appendix A.

The physical capacity of the existing system exceeds anticipated build-out of the service area. Appendix A analyzes system component sizing needed to match anticipated build-out to facilitate sizing of any replacement equipment.

C. North Shore - Eagleridge:

The Eagleridge system currently has one pressure zone served by a booster station with three identical pumps for residential flows and two large pumps to provide fire flow. Residential instantaneous flows are limited by a contract with the City to a flow of 150 gpm. Storage is provided by the City. It has recently been found that the pressure from the City source has increased since the pump station was constructed. Now the City source has a pressure that is only slightly less than that of the Eagleridge system. The City source pressure at the pump station was measured by the District on a chart recorder for one week starting October 30, 2017. The pressure varied from approximately 86-90 psi. The pumps currently increase the pressure to approximately 105 psi. A pressure of 86 psi at the pump station elevation is sufficient to provide greater than 30 psi to all connections under peak hour demand, which suggests that the residential pumps may be taken out of service and that the City source pressure could serve residential demand. Analysis indicates that the two large pumps to provide fire suppression flow may not be necessary but require a more detailed investigation before decommissioning. See Section 3.3.3 for further discussion and analysis.

The physical capacity of the Eagleridge system is analyzed in the same way the south shore system was analyzed in Appendix A. Water demands are discussed in Section 2.1, and MDD (without conservation savings) is 800 gpd/ERU. ADD does not impact physical capacity because the contract with the City does not stipulate a maximum

annual usage. Water rights are not a consideration because the City holds the water rights for the source. Treatment and storage capacity are also not applicable because the City provides these at the contract flow rate of 150 gpm. The distribution system is designed for fire flow, and residential demands are much lower and therefore the distribution system does not limit physical capacity. The only limiting factors are the contract flow rate of 150 gpm and the pumping capacity. A single residential pump can provide 150 gpm at approximately 20 psi pressure boost, and two residential pumps operating in parallel could easily supply more than 150 gpm. Therefore, pump capacity is not a limiting factor in the physical capacity of the system.

Given the contract limit of 150 gpm and the MDD of 800 gpd/ERU (without conservation savings), the existing 2017 system capacity is **85 ERUs** based on peak hourly demand, equation 5-1 from the DOH Water System Design Manual. Build-out for the Eagleridge subdivision and existing customers is 71 ERUs, so the system has capacity for 14 additional ERUs. If conservation savings is realized and MDD decreases to 600 gpd/ERU, the system capacity would be 120 ERUs based on peak hourly demand. This would then allow for 49 additional ERUs beyond the build-out of the Eagleridge subdivision without construction of additional water system facilities.

See Appendix C, the North Shore Water System Consolidation Feasibility study, for discussion of potentially consolidating the Eagleridge and Agate Heights water systems, with the Agate Heights well providing the water source for the combined system.

D. North Shore - Agate Heights:

The physical capacity of the Agate Heights system is analyzed in the same way the south shore system was analyzed in Appendix A. Water demands are discussed in Section 2.1 – MDD (without conservation savings) is 500 gpd/ERU, and ADD (without conservation savings) is 230 gpd/ERU.

Water rights are discussed in the beginning of Section 3 – in summary, the groundwater rights total 438 gpm instantaneous flow and a maximum annual volume of 506.9 acre-feet. Because the source must provide MDD for the system, the instantaneous water rights could serve 1261 ERUs. Based on ADD, the annual water rights could serve 1967 ERUs.

The existing pumping capacity and treatment capacity are the same at 30 gpm. In order for this to provide MDD, the maximum number of ERUs that could be served would be 86 ERUs.

See Table 3.3-6 for a summary of existing storage capacity for the Agate Heights water system. Note that dead storage only includes the 0.5 ft for the physical raised outlet at the base of the tank for both of the reservoirs. No additional dead storage is needed as both of the bases are substantially higher than 46 ft above the highest residence served (providing the required 30 psi at the service meter). Also note that standby storage is nested within fire suppression storage for the upper reservoir while fire suppression storage is nested within standby storage for the lower reservoir. The Fire suppression storage volume for the upper reservoir was set by the local fire

authority for serving the treatment center. Fire suppression for the lower reservoir meets the flow and duration recommended by the Whatcom County Coordinated Water System Plan (500 gpm for one hour).

The number of ERUs in Table 3.3-6 is the maximum capacity of the storage system. The current number of ERUs served by the upper reservoir is 18, so there is capacity for 3 more ERUs to be served by this reservoir. The current number of ERUs served by the lower reservoir is 28, and there are 5 commitments to provide service. Based on the calculations and requirements listed above, this reservoir could serve 89 ERUs total.

The physical capacity of the Agate Heights water system distribution system is analyzed in Section 3.3.3 below. As explained there, the limitation on the distribution system is its ability to provide fire flow rates while maintaining adequate system pressure. The distribution system’s ability to provide peak hourly flow is not a limiting factor, and therefore the distribution system does not limit the physical capacity of the water system.

The above information shows that the treatment capacity limits the capacity of the overall system. The current Agate Heights water treatment plant capacity is 30 gpm during operation. The filter needs to be backwashed once every 10 hours, and the backwash sequence takes 4 minutes. Start-up of the system can take up to an hour. Therefore, a maximum on-line time of the treatment plant is assumed to be 90%. With this and an MDD = 500 gpd/ERU, the treatment plant limits capacity to **77 ERUs**. This is currently the limiting factor in capacity of the system. See Appendix C for further discussion of the possibility of expanding the service area of Agate Heights by adding treatment and storage capacity.

Table 3.3-6: Agate Heights Reservoir Storage Capacity

Reservoir	Operating Storage				Equalizing Storage		Standby Storage		Fire Suppression Storage		Dead Storage	
	Storage Volume (gallons)	Level with Storage Depleted (ft)	Max ERUs	Flow out to other reservoirs (gpm)	Storage Volume (gallons)	Level with Storage Depleted (ft)	Storage Volume (gallons)	Level with Storage Depleted (ft)	Storage Volume (gallons)	Level with Storage Depleted (ft)	Storage Volume (gallons)	Level with Storage Depleted (ft)
Upper (105K gal)	10,046	18.1	21	0	2,831	17.56	9,660	15.74	90,000	0.54	2,644	0.04
Lower (79K gal)	21,149	11	89	21	14,241	8.31	40,940	0.56	30,000	2.63	2,644	0.06

3.3.3 Hydraulic Models and Analysis Results

The program used to perform the hydraulic analysis was InfoWater Version 12.3, the Innovyze water distribution modeling program that is fully integrated with ArcGIS for its graphical interface. Details regarding the set-up and verification of the models is included in Appendix E.

A. Sudden Valley: and

B. Geneva:

The hydraulic model for Sudden Valley and Geneva was updated since the previous water system plan update. Updates included infrastructure for all Developer Extension

Agreements that have been constructed, updates to Maximum Day Demand (MDD) and Peak Hour Demand (PHD), and updates to PRV settings so that the model represents current settings and conditions. Pump curves were updated so that flow rates accurately represented measured flow rates. Fire flow demands were updated to include junctions with new hydrants. The new Division 22 reservoir was added to the model. Elevations were updated to be based on NAVD88 (which is now the vertical datum used by the City of Bellingham).

The modeling performed was for the full anticipated build-out population of Geneva and Sudden Valley based on existing infrastructure (infill of vacant lots). Build-out for Geneva is estimated at 1239 ERUs and build-out for Sudden Valley is estimated at about 3267 ERUs. Scenarios for less than full build-out were not assessed because the system currently has capacity for full build-out.

Summary Analysis Results Model results indicate that there is sufficient pressure and flow to meet the District's peak hourly demand (PHD) and fireflow requirements of 500 or 750 gpm at all current fire hydrants while maintaining minimum pressures throughout the system with a few minor exceptions. The original system was designed to previous State standards (20 psi) and certain lots close to the reservoirs only have 20 psi residual for peak hourly demand conditions. These lots have been identified and qualify for reimbursement by the District for the purchase of a residential booster in accordance with District Resolution 410 (and Resolutions 721, 778, Administrative Code 4.2.1). Because of the low pressures without fireflow, there are approximately five fire hydrants that do not meet 500 gpm minimum, and one capable of supplying 500 gpm but not 750 gpm located adjacent to the commercial or high-density residential areas (URM 12 zoning).

Results indicate that there is sufficient pressure and flow to meet the District's fireflow requirements of 750 gpm at nearly all current fire hydrants in Geneva while maintaining 20 psi residual pressures throughout the system under MDD operating conditions (all are capable of 500 gpm).

In the previous water system plan, there was an area in Geneva where the system pressured exceeded 100 psi. Pressure Reducing Valves were installed at Lowell Ave. and Oriental Ave. in 2012 to remedy three of the four locations. One short dead-end street (Lowe Ave.) still exceeds 100 psi (note that the District requires residential Pressure reducing valves on all services).

C. North Shore - Eagleridge:

The Eagleridge water system model includes all pipes and pumps. The model demands were updated to reflect a MDD of 800 gpd/ERU and a system PHD of 130.5 gpm (based on MDD, build-out of 85 ERUs). Pump curves were updated based on available information. Elevations were updated to all be based on NAVD88 (current datum adopted by the City of Bellingham).

The source from the City of Bellingham was updated to reflect current operating conditions. The connection from the City is at a hydraulic grade of 519 ft.

Summary Analysis Results

The model was analyzed based on the existing configuration with domestic and fire flow pumps. Results indicate that the existing system can provide sufficient pressure and flow to meet Peak Hour Demand for the projected build-out while maintaining a minimum system pressure of well above 30 psi. Results also indicate that the existing system can provide 750 gpm at all fire hydrants while maintaining a minimum system pressure of 20 psi.

Because of the increase in the source (City) pressure from the previous analysis, the possibility of bypassing or eliminating the pump station was investigated. The model indicates that with the three residential flow pumps bypassed and served by the pressure of the City source, 30 psi can be provided to all connections under peak hour demand.

Additional data is needed to analyze whether the City pressure can provide sufficient fire flow without the fire flow pumps.

D. North Shore - Agate Heights:

The Johnson Well Group B system with two connections was not modeled. The Agate Heights system was modeled and is described below.

The Agate Heights water system model includes all pipes, pumps, tanks and pressure reducing valve stations. MDD was updated to 500 gpd/ERU, and PHD was calculated for each pressure zone. PRV settings were updated to reflect current operational settings. Elevations were updated to all be based on NAVD88.

Summary Analysis Results

The results indicate that the system is capable of maintaining the minimum 30 psi pressure during peak hour demands. The results also indicate that the system can provide in excess of 750 gpm fire flows at the Lake Whatcom Residential and Treatment Center (LWRTC) and throughout the residential subdivisions while maintaining the minimum 20 psi system pressure.

With the addition of a second, higher tank to serve the LWRTC, the Opal Terrace pressure zone was converted from being pressurized by a booster pump station to gravity service. While the analysis indicates the pumps should have sufficient capacity to keep up with refilling the tank under maximum day demand (MDD) conditions, staff have indicated that larger pumps would aid in overall system operations. This upgrade will be coordinated with the proposed project to increase the capacity of the Agate Heights Water Treatment Plant.

Hydraulic profile schematics for the District's three Group A systems (South Shore, Eagleridge and Agate Heights) can be found on the following pages (Figures 3.3-2 through 3.3-4). There is no profile for the Johnson Well system since it only consists of a well and two services, and is not expected to expand.

NO.	REVISIONS	BY	DATE

WILSON ENGINEERING, LLC
 805 DUPONT STREET
 BELLINGHAM, WA 98225
 (360) 733-6100 • FAX (360) 647-9061
 www.wilsonengineering.com

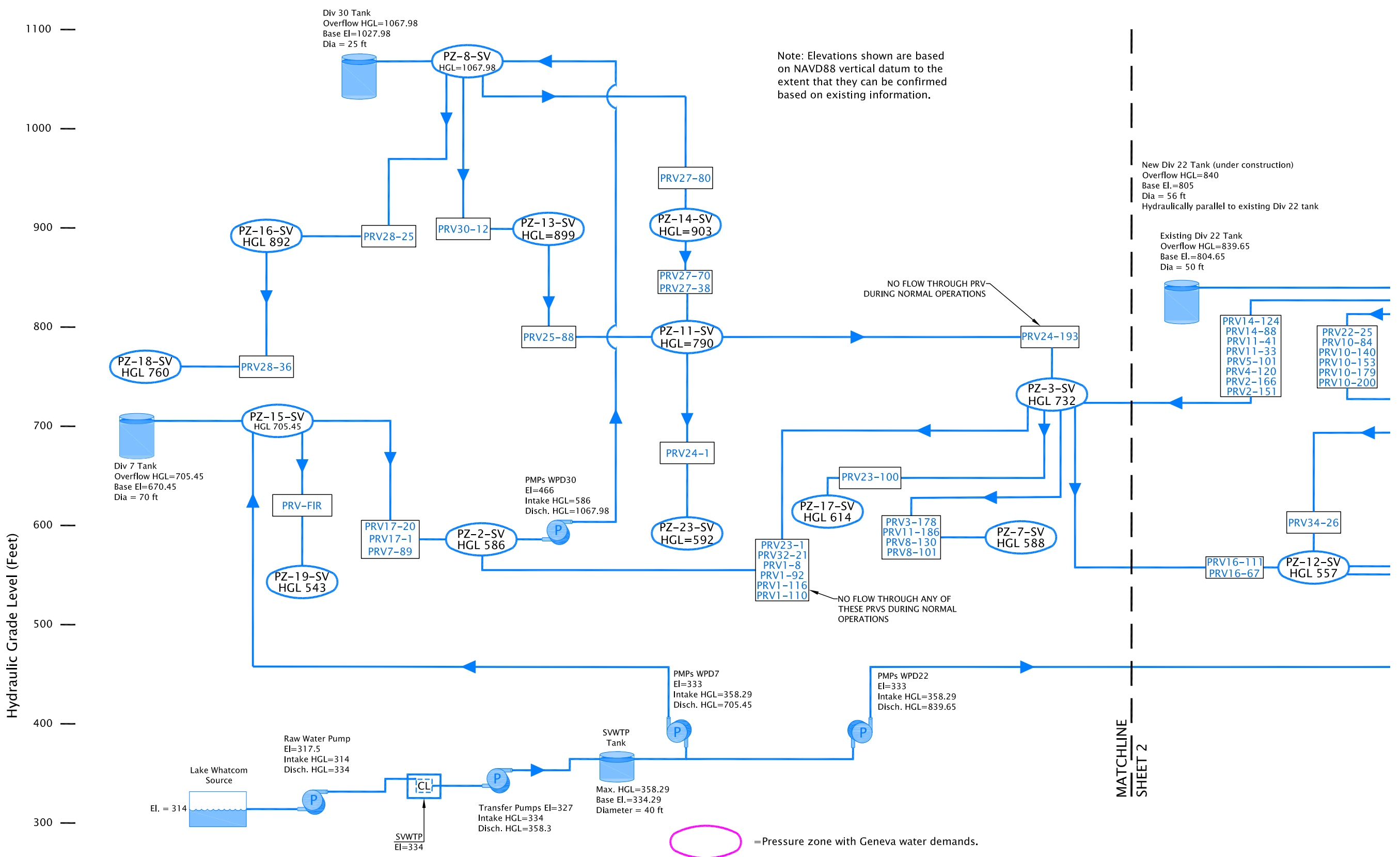

Note: Elevations shown are based on NAVD88 vertical datum to the extent that they can be confirmed based on existing information.

New Div 22 Tank (under construction)
 Overflow HGL=840
 Base El.=805
 Dia = 56 ft
 Hydraulically parallel to existing Div 22 tank

Existing Div 22 Tank
 Overflow HGL=839.65
 Base El.=804.65
 Dia = 50 ft

NO FLOW THROUGH PRV DURING NORMAL OPERATIONS

NO FLOW THROUGH ANY OF THESE PRVS DURING NORMAL OPERATIONS

- =Pressure zone with Geneva water demands.
- =Pressure zone with Sudden Valley water demands.

DESIGNED BY	-
DRAWN BY	RDN
CHECKED BY	BMS

LAKE WHATCOM WATER AND SEWER DISTRICT
 BELLINGHAM WASHINGTON
 FIGURE 3.3-2 HYDRAULIC PROFILE
 SOUTHSHORE - GENEVA/SUDDEN VALLEY

DATE	SEPT 2017	SCALE	NTS	JOB NUMBER	2016-096
SHEET	1	OF	2		

NO.	REVISIONS	BY	DATE

WILSON ENGINEERING, LLC
 805 DUPONT STREET
 BELLINGHAM, WA 98225
 (360) 733-6100 • FAX (360) 647-9061
 www.wilsonengineering.com



DESIGNED BY: -
 DRAWN BY: RDN
 CHECKED BY: BMS

LAKE WHATCOM WATER AND SEWER DISTRICT
 BELLINGHAM WASHINGTON
 FIGURE 3.3-2 HYDRAULIC PROFILE
 SOUTHSHORE - GENEVA/SUDDEN VALLEY

DATE: SEPT 2017
 SCALE: NTS
 JOB NUMBER: 2016-096
 SHEET: 2 OF 2

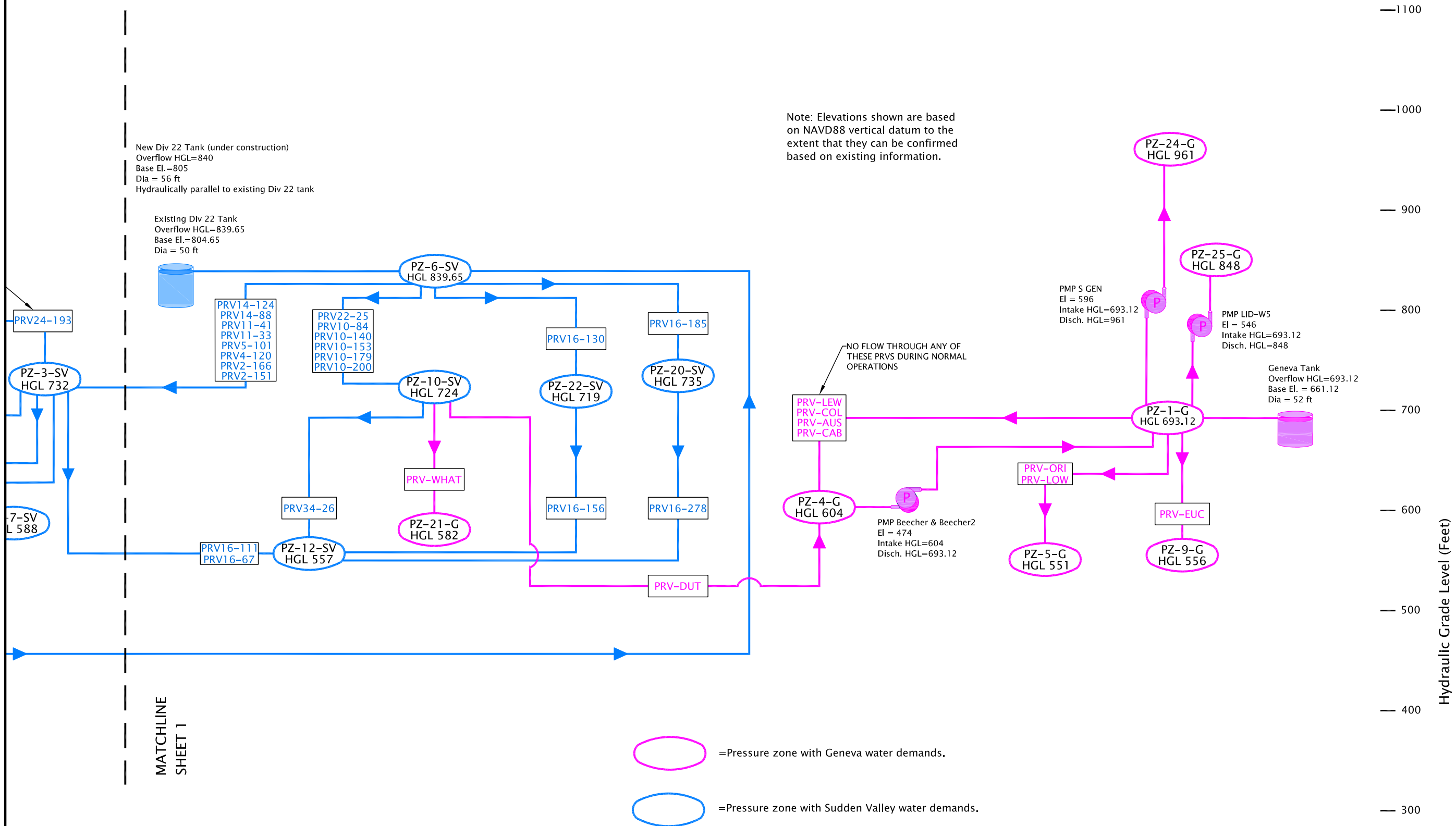

Note: Elevations shown are based on NAVD88 vertical datum to the extent that they can be confirmed based on existing information.

New Div 22 Tank (under construction)
 Overflow HGL=840
 Base EI.=805
 Dia = 56 ft
 Hydraulically parallel to existing Div 22 tank

Existing Div 22 Tank
 Overflow HGL=839.65
 Base EI.=804.65
 Dia = 50 ft

MATCHLINE
 SHEET 1

Hydraulic Grade Level (Feet)

Hydraulic Grade Level (Feet)

700 —

650 —

600 —

550 —

500 —

450 —

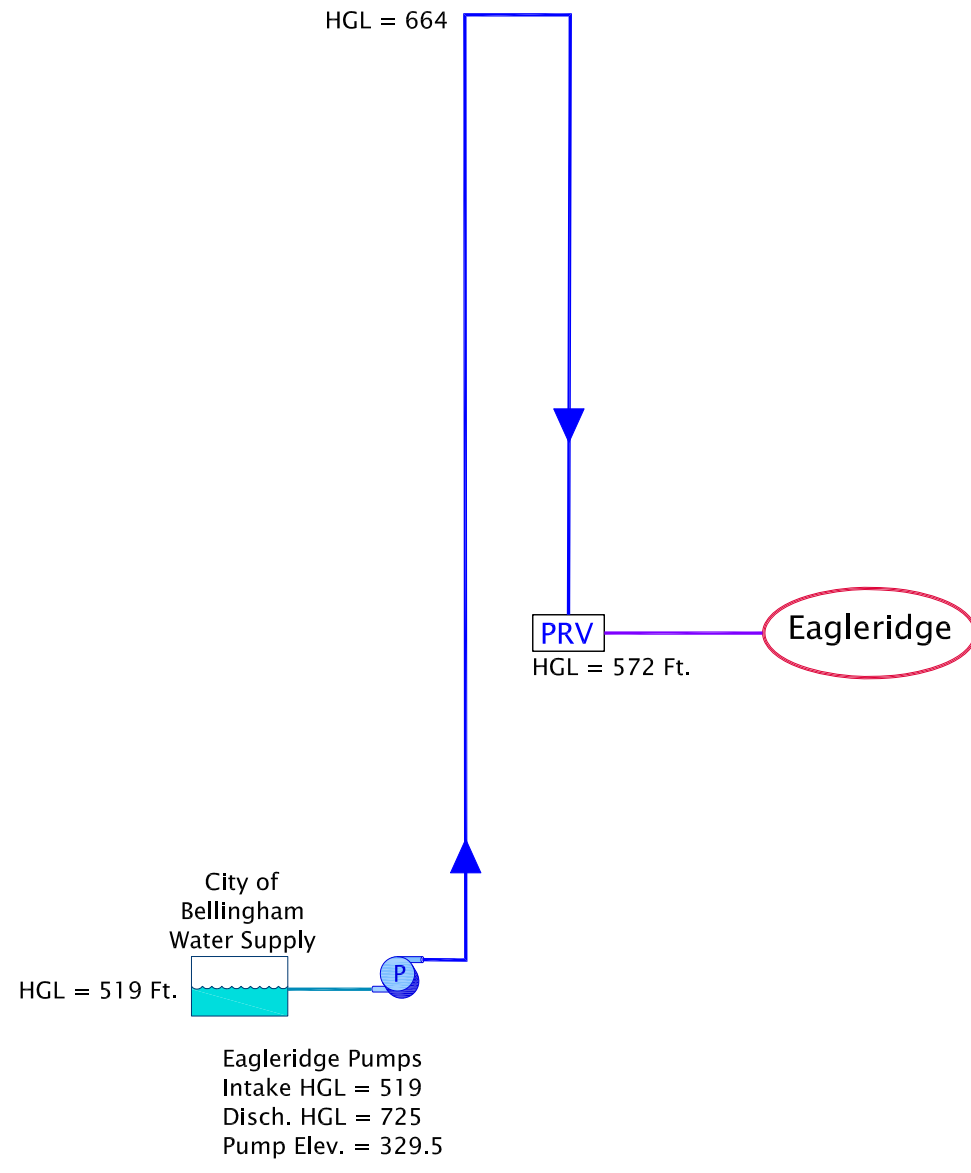

NO.	REVISIONS	BY	DATE

SHEET 1	DATE SEPT 2017	LAKE WHATCOM WATER AND SEWER DISTRICT		DESIGNED BY
	SCALE NTS	BELLINGHAM	WASHINGTON	
OF 1	JOB NUMBER 2016-096	FIGURE 3.3-3 HYDRAULIC PROFILE NORTHSHORE - EAGLERIDGE		CHECKED BY

WILSON ENGINEERING, LLC
805 DUPONT STREET
BELLINGHAM, WA 98225
(360) 733-6100 • FAX (360) 647-9061
www.wilsonengineering.com



Hydraulic Grade Level (Feet)

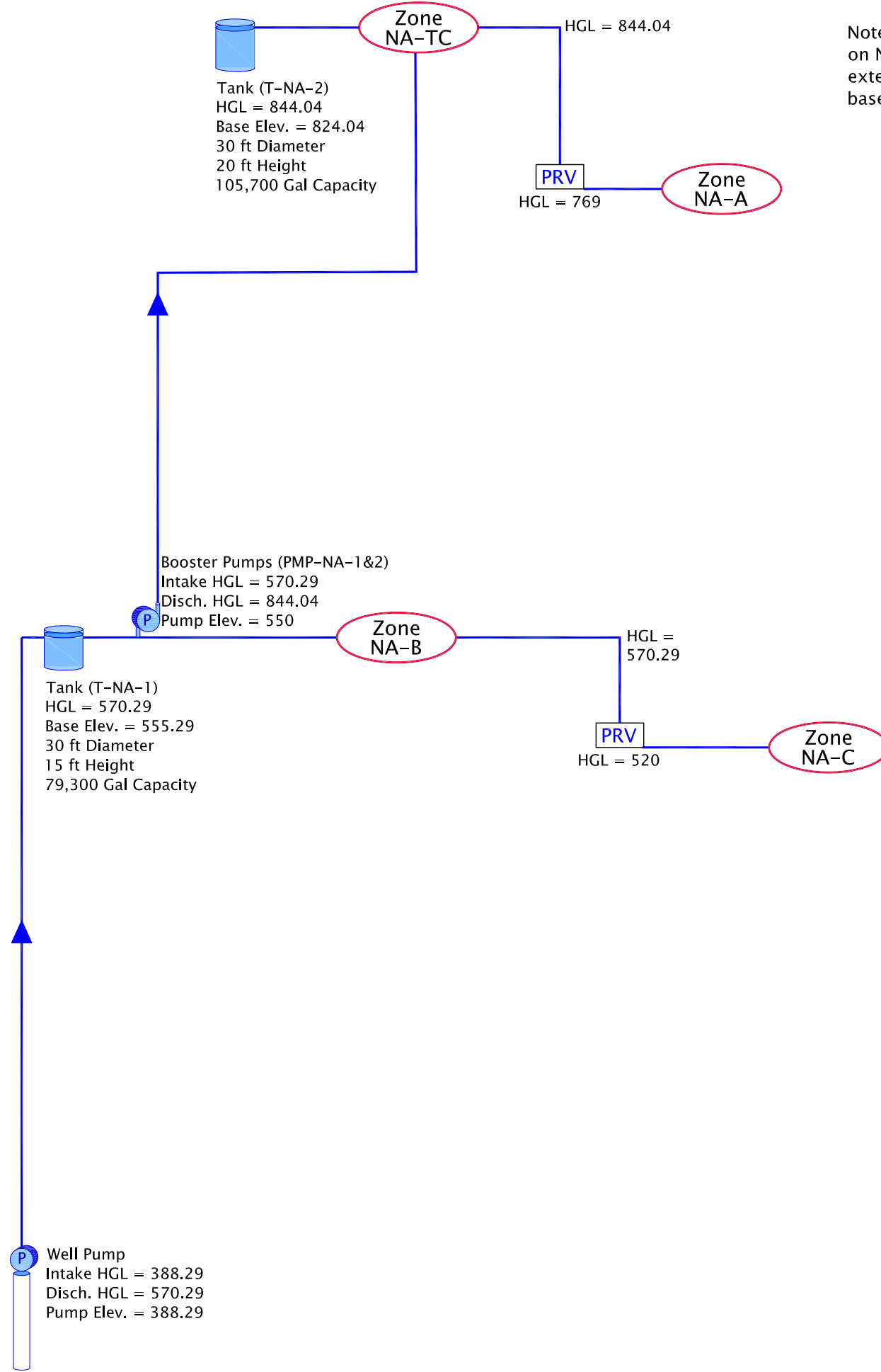

Note: Elevations shown are based on NAVD88 vertical datum to the extent that they can be confirmed based on existing information.

Hydraulic Grade Level (Feet)



NO.	REVISIONS	BY	DATE

SHEET	1	OF	1		
	DATE		AUG 2017	SCALE	NTS
LAKE WHATCOM WATER AND SEWER DISTRICT					
BELLINGHAM WASHINGTON					
FIGURE 3.3-4 - HYDRAULIC PROFILE					
NORTHSHORE - AGATE HEIGHTS					
DESIGNED BY					
DRAWN BY	BMS				
CHECKED BY					
 WILSON ENGINEERING, LLC 805 DUPONT STREET BELLINGHAM, WA 98225 (360) 733-6100 • FAX (360) 647-9061 www.wilsonengineering.com					

3.3.4 Water Rights Evaluation

The District has conducted a water rights self-evaluation and has determined that the existing permitted and certificated water rights it holds are sufficient for the current twenty year planning period. The only shortfall shown is for Eagleridge for the 20-year projection, but it is anticipated (as shown in the Agate Heights self-assessment) that the North Shore consolidation will be complete in twenty years and the Eagleridge area will be served by the Agate Heights well instead of from the City of Bellingham. Section 10.4 – Water Rights includes copies of the District’s water right permits and certificates and completed water right self-assessment forms (DOH 331-372).

A. Sudden Valley Area:

- Source Type – surface water
- Source Location – Lake Whatcom, Basin 3 of the Lake. The intake is 12” diameter, 315 ft from shore and 70 ft deep.
- Purpose of Use – domestic water supply
- Place Of Allowed Use – land within boundaries of LWWSD
- Place of Current Use – south shore service areas
- Time Of Use – See Water Right documents, Section 10.4
- Provisions Or Limiting Conditions – The District has Reservoir Rights, R125120C, associated with Diversion Right # S1-25121P.

B. Geneva Area:

- Source Type – Intertie with Sudden Valley (Lake Whatcom surface water)
- Source (intertie) Location –From Topper Drive, along Dutch Harbor, to Lake Whatcom Blvd.
- Purpose of Use – domestic water supply
- Place Of Use – See Future Service Area, Figure 1-1
- Time Of Use – See Water Right documents, Section 10.4
- Provisions or Limiting Conditions – The District has Reservoir Rights, R125120C, associated with Diversion Right # S1-25121P.

C. North Shore - Eagleridge:

- Source Type – City of Bellingham Intertie (Lake Whatcom surface water)
- Source Location – intersection of North Shore Drive and City limits
- Purpose of Use – domestic water supply
- Place Of Use – See Retail Service Area, Figure 1-1

- Time Of Use – No limits
- Provisions or Limiting Conditions – Supply is limited to 150 gpm domestic, 750 gpm fire flow by agreement with the City of Bellingham.

D. North Shore - Agate Heights:

- Source Type – ground water
- Source Location – Section 24, Township N. 38, Range 3E W.M., Whatcom County
- Purpose of Use – domestic water supply
- Place Of Allowed Use – land within boundaries of LWWSD
- Current Place Of Use – See Retail Service Area, Figure 1-1
- Time Of Use – No limits
- Provisions Or Limiting Conditions – N/A.

3.4 Summary of System Deficiencies

The system analyses did not identify any major deficiencies in any of the service areas. The system deficiencies identified are more areas that could be improved, and are summarized in the following table.

Table 3.4-1 Summary of System Deficiencies				
	Sudden Valley Area	Geneva Area	Eagleridge	Agate Heights
Source	Replace pump motors; improve communications	Convert emergency intertie to PRV	None	None
Treatment	None	N/A	N/A	Additional treatment capacity needed with system expansion
Storage	Reservoir seismic upgrades Reservoir recoating	Reservoir seismic upgrades Reservoir recoating	N/A	Additional storage needed with system expansion
Distribution System	Consider decommissioning some PRVs	Consider PRV for one high pressure area (Lowe)	Consider removing the three low flow pumps and PRV	Replace transmission pumps

3.5 Selection and Justification of Proposed Improvement Projects

A. Sudden Valley Area:

Communications To Water Treatment Plant – It is recommended that communications between the Sudden Valley water treatment plant and the rest of the south shore water system be improved. Methods of doing so should be investigated but could include installing underground fiber optic cable or radio communications.

Distribution System – As the hydraulic profile indicates, there are many connections between pressure zones that have a large number of PRVs connecting two adjacent pressure zones. Having more than two PRVs connecting two pressure zones is generally overly redundant and results in excess maintenance costs. The District is investigating decommissioning some of these redundant PRVs.

Storage – With the addition of the new, second reservoir at Division 22, the South Shore system has sufficient storage for anticipated build-out within the extents of the existing infrastructure.

The Reservoir Seismic Vulnerability Assessment Report details recommended improvements to all of the storage reservoirs in Sudden Valley and Geneva. Before moving forward with performing these improvements, it may be worthwhile to perform an alternatives analysis to compare making seismic and coating improvements/repairs against replacing reservoirs. Items to keep in mind when doing this analysis include:

1. Estimated costs for seismic improvements for each reservoir.
2. Life of coating for welded steel tanks is estimated to be 25 years. None of the existing reservoirs have been recoated and are over 40 years old. Recoating costs are on the order of \$500,000 for a 1MG tank *just for the coating work*.
3. If replacing a tank, may be able to relocate to higher location or construct to be taller to provide adequate pressure to all connections, including those immediately adjacent to tank areas.

B. Geneva Area:

Source Capacity -The intertie between Sudden Valley and Geneva provides sufficient supply capacity to the Geneva area. A backup emergency intertie with the City of Bellingham provides emergency standby capacity. As mentioned previously, the emergency intertie currently consists of a pump station to provide water from the City of Bellingham to the Geneva area. In the time since the Geneva – Sudden Valley intertie was completed and Geneva no longer regularly purchased water from the City of Bellingham, the City has increased its distribution system pressure feeding the suction of that pump station. Investigations have found that that City-side pressure at the existing pump station suction is approximately 160 psi and that the LWWSD-side pressure at the existing pump station discharge is approximately 120 psi. Therefore, for this connection to be functional, the pump station will need to be removed and replaced with a pressure reducing valve.

Storage – The new, second reservoir at Division 22 will provide water service to and storage for the lower zone of Geneva, PZ-4-G. With this addition, there is sufficient storage for the anticipated build-out of the Geneva area.

When the South Geneva pump station and PZ-24-G was added, the intent was that when future development in that area progressed, a reservoir would be built to serve this area by gravity and the booster pump station converted to a transmission pump station to fill the reservoir. With this intent in mind, fire hydrants were installed on the system, although the booster pump station is not sized to provide fire flows and they remain bagged and out of service until the reservoir is constructed. There is currently no timeline or plans for construction of such a reservoir.

LWWSD is investigating removing the 0.07 MG tank that is not currently in regular use. Removing this tank would require the connection with the City of Bellingham to be active and functional so that the connection could serve the Geneva area when the 0.5 MG Geneva reservoir is out of service for cleaning/maintenance. As discussed above, making the connection active and functional will require replacement of the existing pump with a PRV.

Distribution - The District had a prioritized list of aging water mains that are candidates for replacement. Leaking and undersized lines received the highest priority for replacement. To the best of their knowledge, the District has now replaced all AC water mains. Budgetary numbers are included in the ten-year capital facilities plan for additional distribution system improvements such as replacing fire hydrants, blowoffs, air-release valves, and sample stations.

Expansion of Service Area – The District may investigate serving additional areas that have already been developed in the Geneva area. There have been preliminary discussions of consolidating with the Glen Cove water system to the North of the existing service area along Euclid Avenue. The District may also investigate expanding to serve the residences along Lake Whatcom Boulevard between Strawberry Point and Sudden Valley.

C. North Shore - Eagleridge:

Storage – The existing Eagleridge water system currently relies on storage provided by the City of Bellingham. It is anticipated that this will remain until the Eagleridge system is consolidated with the Agate Heights system. See Appendix C for more information on the North Shore Consolidation study.

Distribution - The District will need to replace the pumps and controls at Eagleridge if they are not able to rely on City pressures for normal demands, and/or fire flows.

D. North Shore - Agate Heights:

There have been inquiries over the years by individual residents regarding the possibility of expanding the public water system on the North Shore. Several individual wells and Group B systems suffer seasonal shortages of water. See Appendix C for a thorough discussion on the potential for consolidation of the north shore water systems. In general, the Agate Heights well source has sufficient capacity and water rights to serve all of the development along North Shore Road, including

Eagleridge and existing private Group A and Group B water systems. This would require new pipe and additional treatment and storage capacity depending on the extent of the consolidation.

Water Treatment - The existing treatment plant is limited to 30 gpm, which is far less than the well capacity and water right. In order to provide treated water to additional customers, the package water filtration plant capacity will need to be increased.

Storage – If system consolidation or expansion is pursued beyond the capacity of the existing reservoirs, additional storage will need to be constructed. Options for this are discussed in Appendix C.

Distribution - With the mixed survey results received from potential customers along North Shore Road, the District is carefully considering its role in the expansion of the Agate Heights service area. However, a successful petition for a utility local improvement district or a developer extension request would be considered and would define the extents of that particular distribution expansion. The District anticipates future extensions of water along North Shore Road to the east and to the west.

4. Water Resource Analysis

4.1 Water Use Efficiency Plan Development and Implementation

The District has had a conservation plan in effect since 1988. The District adopted its current Water Use Efficiency Plan in February 2016. The Plan outlines current and future water conservation measures and relevant data. The WUE plan is incorporated here in Appendix B.

The Sudden Valley area had a history of high levels of distribution system losses. The 3 year average distribution system losses (DSL) (2005-2007) were 27.59%. The District has taken actions to decrease DSL, and the 2012-2014 3 year average DSL was 12.86%. Current goals for further improvements in water use efficiency for Sudden Valley include reducing DSL to less than 10%, reducing summer peak usage to 55 gallons per capita per day by 2020, and reducing average annual usage by 2% by 2020. Because current DSL is greater than 10%, the District is implementing water use efficiency measures as detailed in Appendix B.

The Geneva area's 3 year average DSL for 2012-2014 was 9.1%. Current goals for water use efficiency include maintaining less than 10% DSL, reducing summer peak usage to 65 gallons per capita per day by 2020, and reducing average annual usage by 2% by 2020. After replacing over 12,000 feet of asbestos concrete mains in 2015, the District anticipates the DSL to continue going down.

Distribution system losses in North Shore - Eagleridge have been minimal, averaging 2.87% from 2012 to 2014. Current goals for water use efficiency include maintaining low DSL, reducing summer peak usage to 100 gallons per capita per day by 2020, and reducing average annual usage by 10% by 2020.

The North Shore - Agate Heights distribution system losses in 2012-2014 averaged 2.83%. Current goals for water use efficiency include maintaining low DSL, reducing summer peak usage to 75 gallons per capita per day by 2020, and reducing average annual usage by 10% by 2020.

The decreases in distribution system losses is a result of the concerted effort by the District and show the effectiveness of their water use efficiency plan.

4.2 Source of Supply

A. Sudden Valley Area:

The District does not anticipate pursuing additional water rights for the Sudden Valley Area within the next 20 years. The District received Department of Health approval in 1996 for a reduction in source criteria and documented further decreases in water demand that should allow the existing water rights to support full build-out (Appendix B). The Sudden Valley Community Association actively pursued population density reduction in the watershed by acquiring and restricting properties, and reducing dues for consolidated lots. As of August 2015, 1439 of the original lots have either been purchased by the Sudden Valley Community Association and placed under restrictive covenant or consolidated with other lots, which allows the water rights to adequately service full build out (including the Geneva area).

The District's water treatment plant has the ability to produce water for beneficial use up to the level of the existing water rights. The water is needed to serve projected populations within existing subdivisions at buildout for both Sudden Valley and Geneva.

B. Geneva Area:

Geneva is supplied under the Sudden Valley water rights, which are adequate for both systems.

The City of Bellingham has pursued a program to reduce development in the watershed by acquiring and restricting undeveloped properties. These efforts have removed at least 332 future lots (the former Summit View and Cedar Hills West subdivisions) from the Geneva area.

C. North Shore - Eagleridge Area:

The District does not anticipate pursuing any additional water allocation for the North Shore/Eagleridge Area within the next 20 years. The City of Bellingham holds water rights for the existing source. The existing supply agreement with the City (150 gpm domestic flow) is adequate for the Eagleridge Water System to support 85 ERUs without a reservoir. If another ULID is initiated on the North Shore to take residents off of private lake withdrawals, the District may or may not have enough contractual City capacity to serve at that time. If existing residential owners petition for a water ULID, the District will re-evaluate the adequacy of supply at that time and consider the need for a contract increase from the City of Bellingham versus the cost-effectiveness of an intertie with the Agate Heights system, or adding a reservoir to the Eagleridge system. See also Appendix C for further discussion of options to consolidate the north shore water systems.

The Eagleridge Water System has a history of high per-connection water use that has been anecdotally attributed to subdivision covenants requiring green lawns. The peak day per-connection usage is approximately twice as high as the Geneva and Sudden Valley service areas, so there are opportunities for conservation in this neighborhood.

D. North Shore - Agate Heights Area:

The District does not anticipate pursuing any additional water allocation for the North Shore - Agate Heights Area within the next 20 years. The existing ground water rights for the well source exceed current demand, and would support a system expansion or water system consolidation as described in Appendix C.

The Johnson Well currently uses less than 5000 gallons per day and therefore operates as an exempt well which does not require a water right.

4.5 Interties

Existing Interties

Sudden Valley :

Sudden Valley has an intertie with Geneva, which is used to supply Geneva. This is a connection between two District service areas that are now considered one water system (with one DOH system ID number).

B. Geneva :

The Geneva water source is an intertie with the Sudden Valley. The location is from Topper Drive, along Dutch Harbor Road, connecting at Lake Whatcom Blvd., near Strawberry Point. There is also a back-up, emergency intertie with the City of Bellingham, which used to be the primary supply to Geneva. The emergency intertie is located on Lakeway Boulevard at the City limits (Scenic Ave).

C. North Shore - Eagleridge:

The water source for the Eagleridge Water System is an intertie with the City of Bellingham. It was first used in 1989. Its purpose is to supply water to the Eagleridge Water System. The physical capacity of the intertie is 750 gpm and is limited by agreement with the City. The District's Eagleridge booster station currently has the combined capacity to pump 750 gpm (to meet fireflow requirements). The intertie agreement is included in Section 10.2 – Agreements.

D. North Shore - Agate Heights:

There are no existing interties between the Agate Bay water system and the Johnson Well.

New Intertie Proposals

A new intertie between the Agate Heights water system and the Eagleridge water system would be considered if there is sufficient interest in a public water system in the North Shore area. This would be an intertie between two separate District water systems, and would most likely result in the discontinuation of purchasing water from the City of Bellingham. This scenario was explored in detail in the North Shore Consolidation Feasibility study (Appendix C).

4.6 Reclaimed Water Opportunities

Lake Whatcom Water and Sewer District currently sends all sewerage collected to the City of Bellingham for wastewater treatment. Since the District does not have any facilities to process wastewater, and the City's treatment plant is over 8 miles from the District's service areas, there are no immediate opportunities for implementing reclaimed water use within the District. The City currently has no plans to implement any reclaimed water projects. It is unlikely that the District will pursue any reclaimed water projects in the next ten years.

The District did include advanced wastewater treatment as one of the alternatives evaluated in the Final Environmental Impact Statement for South Shore Sewage

Disposal Alternatives (August 1997) although it was not ultimately selected. The wastewater plant would have produced up to 1 MGD of reclaimed quality water.

The most obvious potential consumer of reclaimed water in the District service area would be the Sudden Valley Community Association (SVCA) golf course. However, SCVA holds certificated water rights for withdrawals from Lake Louise which they use for irrigating the golf course. They do not purchase water from the District for irrigating the golf course.

5. Source Water Protection

5.1. Wellhead Protection Program

The North Shore Area is the only District facility with a well as a Group A water source. The Wellhead Protection Plan for this system was previously submitted to DOH, approved in May 2000, and is incorporated herein by reference. Conditions near the District's wells have not changed substantially since 2000. Spill response and notification of emergency response personnel is also covered in the District's Emergency Response Plan.

5.2. Watershed Control Program

The District is a member of the Planning Unit for WRIA 1 and is a member of the Water District Caucus. The District also works with Whatcom County PUD and Whatcom County small cities on water supply coordination and consistency.

The District has actively participated in preparation of the regional watershed control program via the Lake Whatcom Management Program along with the City of Bellingham and Whatcom County. In May 1998, the "Interlocal Agreement Between the City of Bellingham, Whatcom County, and Water District 10 Concerning Joint Management of Lake Whatcom" was adopted. The on-going efforts of the Lake Whatcom Management Program are documented in the five-year Work Plans and updated annually. The District also participates financially in the Lake Whatcom Tributary Monitoring program, led by Whatcom County.

5.3. System Improvements Analysis, Priority, Alternate Selection

There were no water system improvements identified that are associated with the North Shore - Agate Heights Wellhead Protection Plan or the Regional Watershed Protection Plan.

6. Operation and Maintenance Program

6.1. Water System Management and Personnel

The management structure of the District consists of an elected five-member Board of Commissioners who determine policy, set rates, and approve the budget. The Board employs a full-time General Manager who hires additional staff, manages the day-to-day business of the District, and carries out the policies set by the Board. The General Manager is in charge of daily operations and approves expenditures within the budget. The District employs a staff Engineer who is also the Assistant General Manager.

The Board and General Manager are assisted and advised by a consultant attorney firm and a consultant engineering firm. The attorney provides general advice and counsel to the Board regarding the legal requirements of their operations, contracts, permits, personnel, and legal challenges to the District's activities. The consultant engineering firm provides general assistance, surveying, analysis, design, plan review, and construction management services to the District.

In addition to the General Manager and District Engineer / Assistant General Manager, the District staff includes an Office Administrator, Accounting Manager, a Maintenance Supervisor, several maintenance workers, meter reader, and clerical support staff. An organization chart is in Section 1.1, Figure 1-2.

6.2 Operator Certification

The District is required to have Certified Operators including one Water Distribution Manager 1 and one Water Treatment Plant Operator 2. The District is committed to supporting on-going training for its operators to maintain or improve their certifications.

The highest level certifications obtained by current District staff are summarized below.

POSITION	WATERWORKS CERTIFICATIONS							
	Backflow Assembly Tester	Cross Connection Control Specialist	Water Distribution Manager in Training	Water Distribution Manager 1	Water Distribution Manager 2	Water Treatment Plant Operator in Training	Water Treatment Plant Operator 1	Water Treatment Plant Operator 2
Engineering Technician		X			X			X
Maintenance Supervisor	X	X			X			X
Maintenance Worker		X			X			X
Maintenance Worker Specialist 1		X		X				X
Maintenance Worker Specialist 2					X			X
Maintenance Worker Specialist 3				X				X
Utility Systems Support Specialist				X				
Utility Worker			X			X		
Utility Worker			X			X		
Water Treatment Plant Operator	X	X			X			X

6.3 System Operation and Control

The District's water system operation and control can be divided into two categories: Water Treatment, and Distribution/Transmission. The District operates the Sudden Valley Water Treatment Plant (SVWTP) which serves the Sudden Valley area and Geneva area; and the Agate Heights Water Treatment Plant (AHWTP) which serves the North Shore - Agate Heights area. Source water for Eagleridge is purchased from the City of Bellingham. The operation and control of the SVWTP is described in detail in the *Sudden Valley Water Treatment Plant Operations Plan* (revised April 2017). The operation and control of the AHWTP is described in detail in the *North Shore Well and Water Treatment System Management and Operations Manual* (revised April 2017). These documents cover the identification of major system components, routine system operation, preventive maintenance program, and equipment, supplies and chemical listing for the water treatment plants, and are incorporated here by reference.

System Operations and Control for the Distribution/Transmission for the water systems in the District's Areas can be addressed together. The District Engineer is responsible for planning routine and preventive maintenance activities. The Tables below summarize the daily, weekly, monthly, and annual activities associated with the major system components. Routine operations also include utility locates, service installations, investigation of customer complaints, and real estate/rental closings on an as-required basis.

Major System Component	Daily	Weekly	Monthly/Bi-monthly	Annual
Master Meter (Agate, Eagleridge, Dutch Harbor)	Record meter reading			
SCADA/Chart Recorders	check data	replace chart		
Pump Stations (Agate, Eagleridge, Lookout, Div 30)		visual inspection, pump operation check		
Generators (Agate, Eagleridge, Div 30)		automated test		
Reservoirs (Agate, Geneva, Sudden Valley)		visual inspection		
Distribution mains (all)	Cl residual test	Coliform sample		
Meters (all)			Meter reading (Bi-monthly)	
Maintenance Planning			Monthly calendar	Annual plan

Major System Component	Activity	Frequency
PRVs (Geneva, SV, Agate)	Pressure check, visual inspection, repair as needed	Annual
Fire Hydrants (all)	Hydrant flushing (also blow-off flushing)	Annual
Booster Stations (Geneva-2, NS-Eagleridge, Agate)	Inspection, preventive maintenance checklist (i.e. greasing, check voltage, amp draw, ...)	Annual
Generators (Geneva, SV, Eagleridge, Agate)	Inspection, preventive maintenance checklist (i.e. greasing, check voltage, amp draw, ...)	Annual
Reservoirs (Geneva, SV, Agate)	External inspection of screens, foundation Exterior pressure washing Interior inspection/cleaning	Annual 3 years 10 years
Distribution mains (all)	Exercise all valves (concurrent with hydrant flushing) Blow-off flushing of problem dead end lines	Annual Semi-annual
Meters/services (all)	Rebuild/replace aging services	Multi-year plan

6.4 Water Quality Monitoring

The District's water quality monitoring schedules are included in Appendix L. The coliform monitoring plan was updated in April 2017 to comply with the Revised Total Coliform Rule and the Groundwater Rule and was approved by the Department of Health. The coliform monitoring plan and sampling procedures are incorporated here by reference.

6.5 Water System Reliability Analysis

Emergency Response Program

The District's emergency response program for the water treatment plant is described in detail in the *Sudden Valley Water Treatment Plant Operations Plan* (revised 2017). A District-wide Emergency Response Program has been developed as a stand-alone document. This plan covers both water and sewer emergencies and is incorporated herein by reference. An emergency notification procedure for residences that draw untreated water direct from Lake Whatcom is included in this plan.

Water Shortage Response Planning

Since seasonal water shortages have never been a problem for any of the District's water sources, water shortage would probably only occur as the result of a catastrophic emergency, such as major earthquake, volcanic eruption, or explosion, or a prolonged drought. The District has developed a stand-alone Emergency Response Plan to address catastrophic emergencies.

Monitoring Well Levels

The Agate Heights (a.k.a. Giesbrecht) 10-inch well is an artesian well and therefore does not have a traditional well level to be monitored. The District does have a pressure gage on the well supply and they record the static pressure periodically.

The Johnson well is also an artesian well and only has two services connected. Monitoring will not be performed at that location unless use increases.

Summary of System Reliability Efforts by Area

A. Sudden Valley Area:

Source Reliability – The intake depth and location in Basin 3 provides high confidence in the reliability of the water quality and quantity. Lake Whatcom water quality has been, and continues to be, extensively monitored by the City of Bellingham and other groups. The District's Final Environmental Impact Statement (1997) for South Shore Sewage Alternatives presented an extensive literature review of water quality monitoring results. There continues to be scientific disagreement regarding indicator parameters and interpretation of trends.

Water Right Adequacy – Assuming historic usage patterns remain constant, the existing permitted and certificated water rights (shared with Geneva area) are adequate for the current 20-year planning period, and should be adequate for full build-out. (See Section 2.2) On a state-wide basis, the Department of Ecology may attempt to recall portions of certificated water rights not already put to actual beneficial use. Such an agency action might impact the District's ability to make long range commitments to serve vacant, platted lots. The extent of such potential problems and resolutions cannot be predicted at this time because the District has a combination of certificated and permitted water rights.

Facility Reliability – The Sudden Valley water system was originally designed to provide 500 gpm of fire flow throughout the system. The District goals are to meet the standards of the Whatcom County Coordinated Water System Plan (CWSP) - 500 gpm for 60 minutes for UR3 and RR2 zoning; and 750 gpm for 60 minutes for resort commercial and URM12 zoning. The current system can meet these fire flow requirements on top of the buildout projected Maximum Daily Demand (MDD) for the of the fire hydrants. The Area also includes R2A and Rural forestry zoning for which there is no fire flow requirement in the CWSP.

All water booster stations have redundant pumps and standby power for facility reliability.

B. Geneva Area:

Source Reliability – The water source for Geneva is the same as Sudden Valley, see above for detailed information. An emergency intertie with the City of Bellingham also exists as backup. The City draws its water from Lake Whatcom. Reliability of source water quality is the purview of the City of Bellingham.

Water Right Adequacy – Assuming historic usage patterns remain constant, the existing permitted and certificated water rights (shared with Sudden Valley area) are adequate for the current 20-year planning period, and should be adequate for full build-out. (See Section 2.2)

Facility Reliability – The Geneva water system is capable of providing 750 gpm of fire flow throughout the system. The District’s current goals for fire flow in Geneva are to meet the standards of the Whatcom County Coordinated Water System Plan - 750 gpm for 60 minutes for UR zoning (to match that of adjacent municipal corporation). The current system can meet these fire flow requirements on top of both the buildout projected MDD. The Geneva Area also includes R2A and Rural forestry zoning for which there is no fire flow requirement in the Whatcom County Coordinated Water System Plan.

C. North Shore - Eagleridge:

Source Reliability – The water source for Eagleridge is the City of Bellingham. The City draws its water from Lake Whatcom. Reliability of source water quality is the purview of the City of Bellingham. Water quantity is limited by agreement with the City and is delivered through a single intertie. The City provides standby storage. The booster station has redundant pumps and dedicated standby power. As noted elsewhere, the District may be able to remove the domestic flow pumps and have a direct connection to the City system.

Water Right Adequacy – Water is supplied to Eagleridge through a single intertie with the City of Bellingham. Capacity is limited by agreement to 150 gpm domestic use and 750 gpm fireflow. The existing booster pump station and intertie capacity are more than adequate for ultimate buildout of Eagleridge. In the event of the existing residential owners in the area petitioning for a water ULID, the District will re-evaluate the adequacy of supply and consider the need for a contract increase from the City of Bellingham, or potentially connecting Eagleridge to the Agate Heights water system.

Facility Reliability – There were no issues identified with regard to facility reliability associated with the Eagleridge Water System.

The Eagleridge water system is capable of providing fire flow capacity of 500 gpm. This is more than adequate for the rural zoning (CWSP: 500 gpm for 60 minutes) and matches the City of Bellingham standards.

D. North Shore - Agate Heights:

Source Reliability – The water source for the Agate Heights water system is a 10-inch artesian well. Water quantity is currently limited by the water treatment plant capacity. Standby storage is provided by two concrete tanks. The pump stations both have redundant pumps and dedicated standby power.

Water Right Adequacy – The District has two water right permits and a water right certificate associated with the system well. If historic usage patterns remain constant, the existing water rights are adequate for the current 20-year planning period, and should be adequate for full build-out, including potentially serving a water ULID for the residential properties along North Shore Road (see Appendix C).

Facility Reliability – There were no issues identified with regard to facility reliability associated with the Agate Heights Water System. The Agate Heights water system is capable of providing fire flow capacity of 500 gpm.

6.6 Sanitary Survey Findings

South Shore

The Department of Health performed a sanitary survey of the South Shore water treatment plant in August 2017. This survey did not identify any significant deficiencies or findings. It did recommend items for follow-up action.

One recommendation was to consider adding flow meters in to and out of the CT reservoir to more accurately calculate the T portion of the CT calculation for disinfection. The flow rate out of the CT reservoir is currently measured with flow meters on the transmission lines to Division 7 and Division 22. Adding a flow meter on the pipe flowing in to the CT reservoir would allow the CT calculation to be more accurate in that it could use whichever flow rate was larger (in or out of the CT tank) to calculate the hydraulic residence time. However, using only the flow rate out of the tank will always be either accurate or conservative in the calculation of hydraulic residence time. The cost to add a flow meter on the pipe coming in to the CT tank would not be justified because the currently measured flow rate out of the CT tank is sufficient for the calculation.

Other recommendations in the sanitary survey letter included investigating techniques to lower backwash water use, and investigating Extended Terminal Subfluidization Wash (ETSW).

North Shore - Agate Heights

The Department of Health performed a sanitary survey of the Agate Heights water system in August 2017. The survey did not identify any significant deficiencies or significant findings, but it did identify one observation and two recommendations.

The observation was that the Wellhead Protection Plan has not been reviewed or revised since it was first completed (in 1999). To address this, it was recommended to review this information on some routine schedule to verify that land uses have not changed within the wellhead protection area and to ensure that all current property owners have been notified. This is being addressed in this Water System Plan in Appendix M.

The recommendations are that the insulation around the well be cleaned up and re-done if it is still needed, and that the unknown conduit entering the well head be investigated. These maintenance items are added in Section 6.10 below.

6.7 Cross-Connection Control Program

The District's Cross-Connection Control Program was authorized and implemented by Resolution No. 227. The Resolution adopted the American Water Works Association, Pacific Northwest Section's "*Accepted Procedure and Practice in Cross-Connection Manual*" as the procedural manual for implementing the cross connection control program. Resolution No. 227 is included in Chapter 10.1 – Supportive Documents, and the "*Accepted Procedure and Practice in Cross-Connection Manual*" is incorporated herein by reference.

The District conducts annual tests of all District backflow prevention equipment. The District sends the results to the City of Bellingham since the equipment tested is located at the interties with the City's water system. The District also maintains a list of privately owned and maintained backflow prevention equipment, and notifies the owners when it is time for required annual testing. The customers send their test results to the District, where they are reviewed and kept on file.

6.8 Customer Complaint Response Program

The District's Customer Inquiry/Complaint Response Program focuses on service to customers and is outlined on the following page, which contains the District's Inquiry/Complaint form. The District's procedure starts with a customer contacting the District, usually by phone, and the administrative staff person fills out the first part of the form. Forms with service complaints are then passed on to the Engineering Tech for input into the tracking system. The maintenance supervisor reviews the complaint, then he assigns a maintenance staff member to investigate the complaint. If possible, this staff member resolves the issue. If not, the staff member reports back for further review and direction. Once the item is resolved, the resolution is recorded in the tracking system.

Approximately half of the Water Service Inquiry or Complaint forms are inquiries, for example general service questions, or requests for water quality reports instigated by Customer Confidence Report distribution. The majority of the complaint forms are regarding low pressure, with some chlorine odor complaints.

The District has developed a Waterborne Illness Procedure which requires that any report concerning possible waterborne illness be reported immediately to the Whatcom County Health Department. The full procedure is found in the District's Policy and Procedures Manual.

6.9 Record Keeping and Reporting

The District maintains the following types of records at its headquarters and/or operations buildings:

- water quality (various parameters) at the Sudden Valley Water Treatment Plant and Agate Heights Water Treatment Plant
- water quality in all distribution systems

- meter readings (customer and master meters)
- repair records
- reservoir levels
- equipment maintenance records
- customer service requests
- customer complaints and inquiries
- rainfall

The District follows a formal records retention schedule detailing the type of records, the required statutory retention period, and the District retention period. The District also maintains an active file index and an inactive/archive records index. The Records Retention Policy is incorporated here by reference.

The water plant operator is responsible for scheduling and conforming to all DOH reporting requirements.

6.10 O & M Improvements

The District's asset management program tracks the condition and remaining useful life of the District's assets and assesses maintenance needs to maximize the value of the assets. Some of the more significant maintenance and operational improvements are discussed below.

Sudden Valley and Geneva:

Treatment Plant Maintenance

There are a number of recommended maintenance items within the Sudden Valley Water Treatment Plant, described below.

1. Have a concrete inspector inspect cracks in the concrete walls and inspect the clearwell basin below the filters.
2. Address relatively minor corrosion problems in the upper portion of the flocculation tank.
3. The filter media should be investigated. Media could be sampled throughout the depth of the filter to see if there is any bacterial fouling (unlikely with pre-chlorination), deposition of mineral deposits, or rounding of the media. Media characteristics could be compared to AWWA Standard B100. If the media was sufficiently out of the specification, replacement should be considered. The media has not been replaced in many years, if it ever has. The filter underdrains should also be inspected.
4. Replace hydraulically activated flow control valves (Cla-val) with electronically controlled flow valves (to have better control of flow rate going to filters)
5. Replace all 1720E Hach turbidimeters (either with new Hach turbidimeters or other) (1720E stopping being produced)
6. Replace Hach 9184 chlorine analyzers

North Shore – Agate Heights

Maintenance items for the Agate Heights system include cleaning up and replacing the insulation around the well if it is still needed, and investigating the unknown conduit entering the well head.

6.11 Safety Procedures

The District has adopted the Safety Manual supplied by Water and Sewer Risk Management pool. A copy of this Manual is provided to each employee. The Manual included chapters on Safety Responsibility, Confined Space Entry, Lock-out/Tag-out, Rescue Procedures, Respirator Protection, Accident Prevention and Investigation, Hearing Safety, Meter Reading Safety, Back Injury Prevention, Poisoning and Insect Bites and Stings, and Bomb Threat Training.

Material Safety Data Sheets are kept at the office and posted where the chemical is used. Safety and First Aid equipment owned by the District includes a manlift, ventilation blowers, self-contained breathing apparatuses, respirators, personal protective equipment, 3 gas detectors, and first aid kits in each truck and at the office. All personnel are required to attend monthly safety meetings and to take Safety training classes including First Aid and CPR certification. District staff have also completed numerous additional safety related classes.

7. Distribution Facilities Design and Construction Standards

7.1 Project Review Procedures

For District-initiated projects, the District's project engineer prepares the project reports and construction documents and conducts an internal quality assurance review. The District's staff engineer performs an independent review of the work completed by the project engineer. The District's senior field staff review distribution system plans to confirm that existing system information is correctly shown, and proposed connections are feasible with respect to valve arrangements.

The District's General Manager also reviews project documents to assure that general District goals have been addressed by the project. The General Manager's review is not intended to be a detailed engineering design review such as that performed by the Department of Health project engineer.

For projects covered by Developer Extension Agreements, the developer's engineer prepares the project reports, plans and construction documents, and the District's engineer reviews them. If the project includes more than water distribution mains, the project reports, plans and construction documents are sent to the State Department of Health for review and approval.

The District requests advance approval of their design and construction standards in order to be eligible for project review exception for distribution main projects. This request is noted on the District's water system plan review application.

7.2 Policies and Requirements for Outside Parties

The District's design and construction standards apply to outside parties and include requirements for utility easements and pipe looping. The District has adopted a standard Developer Extension Agreement (DEA) template (included in Appendix G). Each application to enter into a DEA is evaluated against the District's Comprehensive Plans to determine specific requirements that may be imposed, and against Resolutions that may require special fees.

7.3 Design Standards

The District's design and construction standards are included in a stand-alone document titled *Lake Whatcom Water and Sewer Design Standards and Construction Standards and Details – September 2017*. The District requests concurrent DOH approval of these updated design and construction standards, included herein as Appendix H.

7.4 Construction Standards

See 7.3 above and Appendix H.

7.5 Construction Certification and Follow-up Procedures

The District requires an inspector for both District-initiated and developer extension construction projects. The inspector checks all materials at the site against approved submittals, advises the project engineer of job progress, conditions and concerns. The inspector or the District's designated representative witness all pressure tests, water quality sampling, and startup. District field crew make, or directly supervise, all new water connections to the existing system. Tests are conducted in accordance with the District's Standards and WSDOT Standard Specifications.

Upon completion of the project, the District's project engineer signs and submits the Certificate of Completion form to Department of Health, if required, or provides the Certificate of Completion form to the District for their records.

8. Improvement Program

8.1 Prioritizing Potential Improvements

8.1.1 Identification of Potential System Improvements

The District has compiled a Capital Improvements Plan which is used to track needs, scheduling, and completion of all projects and major activities for the water and sewer missions of the District.

The Capital Improvements Plan list is included in Appendix I – Capital Improvements Plan. This list includes all planned water projects and the proposed schedule for implementing the projects.

The District has four welded steel distribution reservoirs that are over 40 years old and need seismic retrofits and re-coating. Two of these reservoirs are oversized - Division 7 was always larger than it needed to be, and Geneva has had excess capacity since the installation of the Intertie.

Other potential system improvements identified include increasing the Agate Heights water treatment plant capacity, and reducing the number of PRVs in Sudden Valley.

Storage Reservoirs

All of the storage reservoirs in Sudden Valley and Geneva are made of welded steel and require protective coating on the interior and exterior to prevent corrosion. Inspections have been performed on the reservoirs. It is likely that most will require re-coating. A thorough coating inspection on the interior and exterior of all of the reservoirs (except the new Division 22 reservoir) is recommended. It is also recommended that each of the storage reservoirs be cleaned. Previous cleaning and inspection activities have been conducted with the reservoirs on-line.

The results of the Reservoir Seismic Vulnerability Assessment (2016) should be considered in conjunction with reservoir maintenance. It is possible that it may make sense to replace one or more of the existing reservoirs instead of taking them out of service for cleaning, re-coating, and seismic retrofits. This seems especially true for the Division 7 reservoir where a new reservoir could be significantly smaller than the existing reservoir (based on projected build-out demand as detailed in Appendix A) and could perhaps be constructed at a higher elevation so that services near the reservoir receive the appropriate water pressure (as discussed in Section 3). A full alternatives analysis for this is recommended.

Taking the reservoirs out of service for re-coating and/or seismic retrofits may be operationally challenging because some of the pressure zones can only be fed by a single reservoir. Division 22 is now facilitated because there are two reservoirs and the old one can be offline while the new one remains online. The area fed by the Geneva reservoir could be served by the emergency intertie with the City of Bellingham once the intertie pump is replaced with a pressure

reducing valve as described in the capital improvement plan. But serving the areas fed from the Division 7 and Division 30 reservoirs during their outages would be more challenging and would need to be further investigated.

8.1.2 Assessment of Alternatives

Most of the Operations, Maintenance, and Infrastructure projects listed in the Capital Improvements Plan do not require analysis of alternatives so much as a balancing any emerging urgency of need with the District's ability to respond and pay for it at an appropriate level of rates and charges. Most of the projects listed are to replace aging infrastructure (water mains, PRVs, fire hydrants) which will be done in accordance with the District's standards. For those larger projects that do need an analysis of alternatives, a pre-design report will be prepared specifically for each project.

Since the District does not initiate developer projects (DEAs), it also does not assess alternatives for DEAs in advance. The schedule for these projects will depend upon the developer's assessment of market demand, cost, and the ability to obtain environmental permits and approvals. When they occur, development projects will be required to fit into a framework that improves, rather than hampers, the District's ability to operate in the public interest, safely and cost-effectively.

8.1.3 Selection of Alternatives

Since there are many factors involved in the sizing, site selection, operational issues, and reservoir allocation, a specific alternative for reservoir rehabilitation (seismic upgrades, re-coating) vs replacing with smaller reservoirs for the Division 7 and Geneva reservoirs has not been selected at this time. A detailed analysis will be conducted and included in the Project Report when the projects are undertaken.

8.2 Improvement Schedule

The improvement schedule is incorporated in the District's Capital Improvements Plan, included here in Appendix I.

The District has several projects identified that are not yet on the schedule. These are also listed in Appendix I.

9. Financial Program

Lake Whatcom Water and Sewer District is a public water system with 1,000 or more connections, not regulated by the State Utilities and Transportation Commission.

9.1 Past and Present Financial Status

Summaries of the District's operating income and expenses for the past 6 years are included in Appendix F – Financial Data. The reader should note that the District balance sheet includes a large amount of depreciation, and it does not operate with negative cash flow.

The District's 2016 and 2017 operating budgets are also included in Appendix F – Financial Data.

The District's past and present plan for financing major water system improvements is to use a combination of revenue from water rates (General Fund), connection fees (Construction Fund), Utility Local Improvement Districts (ULIDs), and Developer Extension Agreements (developer financed). Both revenue bonds and low-interest Drinking Water State Revolving Fund and Public Works Trust Fund loans have been used for cash flow to construct projects. The long-term debt for both sources is retired with a combination of General Fund (existing customer) and Construction Fund (future customers) moneys.

9.2 Available Revenue Sources

Anticipated revenue sources for making system improvements include connection fees, water rates, utility local improvement districts and developer extension agreements.

9.3 Allocation of Revenue Sources

The District has a combined rate structure applied to all service areas, replacing the previous area-specific rate structure. The District's sewer system rate structure has been combined for all areas since approximately 1994.

The Capital Improvement Plan includes an assessment of the beneficiaries of each improvement and allocates costs by new vs existing customers. Connection fees are used to pay for improvements that benefit new connections; water rates are used to pay for improvements that benefit existing customers; Developer Extension Agreements pay for system extensions/improvements that benefit development (typically new subdivisions or extensions to previously unserved areas). The costs to construct and /or operate improvements that benefit more than one customer class are allocated on a percentage benefit basis.

9.4 Program Justification

Projected revenue requirements are included in the most recent Capital Improvement Plan draft dated November 2017. For District-funded projects, the

District has the ability to secure these funds through assessment of rates and charges. Developer extensions are funded directly by the developer, and the District requires a performance bond when construction begins to ensure the project is completed in accordance with District requirements. Utility local improvement districts are typically formed at the request of the parties in a benefiting area, and guarantee payback to the District for investing in new infrastructure while allowing the benefiting parties to pay off the costs over time.

9.5 Assessment of Rates

LWWSD's Master Fees and Charges Schedule is included in Appendix F – Financial Data. These rates are continuously reviewed and adjusted in consideration of operating costs and proposed capital improvements identified in this plan. The District Commissioners periodically review the planned projects included in the District's Capital Improvements Plan. When substantial changes are made to the capital facility plan, the Commissioners review the impacts on rates and charges and make adjustments accordingly. The Commissioners adopted a rate structure that promote water conservation. The District completed their most recent rate study update in January 2017.

10. Miscellaneous Documents

10.1 Supportive Documents

State Environmental Policy Act – Environmental Checklist
Determination of SEPA Official
Certification of Registration from the Department of Revenue
Water Facility Inventory forms for each system
Cross Connection Control Program. Resolution No. 227
Requirements for Water and Sewer Service, Resolution 757
Cross Connection and Residential PRVs, Resolution 784
Residential Booster Pump Credit, Resolution 410