



2025

Water & Sewer Permit Application Packet

Last updated 1/2/2025

Table of Contents

Permit Process Flow-Chart	2
Application for Water/Sewer Permit	3
Letter to Applicants on Service Installation & Inspections	6
Connection Fee Components and Charges	7
Preconstruction Meeting Checklist	8
Grinder Pump Service Checklist.....	9
Whatcom County Water and Sewer Availability	10
District Sewer-Only Will-Serve Letter	11
Water and Sewer Permit Checklist	12

Pages 15-41: Water & Sewer Service Construction Details: G1, G2, G3, G6, G8, W1, W2, W10, W11, W13, S1, S2, S8, S9, S10, S11, S12, S13, S14, S15, S16, S17, S18, S20, E1, E2 and E6 (these standards are most applicable to residential water and sewer projects, a complete set of Design & Construction Standards is available on the District website).

PERMITS ARE ISSUED BY APPOINTMENT ONLY

- Complete the Application for Water/Sewer Permit, pages 3 – 5, from the permit packet and submit the application, with the required documents listed on page 13, to the Lake Whatcom Water & Sewer District office. Keep remaining pages for your reference.
- When the permit is ready a District representative will contact you to set up your permit intake and payment appointment.
- The Bonded Side Sewer Contractor List is a separate list available at the front counter or online at <http://www.lwwsd.org>.

LAKE WHATCOM WATER & SEWER DISTRICT PERMIT PROCESS

the permit process is easy with proper planning

Work within the Lake Whatcom Watershed is subject to work restrictions from October 1 through May 31 when exposed soils exceed 500 SF

AVAILABILITY FORMS

If water and sewer is available, an availability form is typically issued within 2 business days. Connection location information is provided within approximately 2 weeks after staff visits the site and determines connection locations.



DETERMINE AVAILABILITY

Contact the engineering department to determine water and sewer availability for your project. Staff will review and get back to you with project requirements.



ISSUE PERMIT

Submit permit application, a copy of the Whatcom County issued Building Permit and approved site plan. Staff will prepare the permit.



Call the District office, 360-734-9224, to arrange payment. Payment for your permit is due *before* construction starts. Permits are valid for 365 calendar days from the date of issue.

SCHEDULE PRE-CONSTRUCTION MEETING

After the permit is paid and issued, Bonded Side Sewer Contractors call 360-734-9224, at least 2 business days in advance, to schedule a pre-construction meeting before construction and for all inspections.



SIDE SEWER LATERAL CONSTRUCTION

Your side sewer lateral must be installed by a contractor on the District's approved list (see lwwsd.org for a current list). All work must be inspected and meet District Standards.



WATER SERVICE INSTALLATION

After the pre-construction meeting, and when site is prepared, call the District to schedule the water service line install from the main to meter box. Allow approx. 14 days for this work.

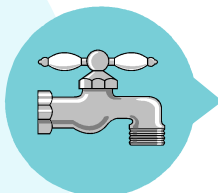

Customers install the water service line from the building to the meter and the PRV near the meter box. Service lines and PRV must meet District Standards. Call the District to schedule a PRV inspection.

YOU DID IT!
WE LOOK FORWARD TO SERVING YOU

BEGIN SERVICE

Contact the District office when you are ready for service. Services can begin when all permit requirements are met, including the installation of the PRV and passing the Cross Connection Survey. Billing begins when the water meter is unlocked



CONTACT INFORMATION

District website: [http:// www.lwwsd.org](http://www.lwwsd.org)
District office: 1220 Lakeway Drive | Bellingham, WA 98229
Telephone: (360) 734-9224



LAKE WHATCOM WATER AND SEWER DISTRICT
Application for Water/Sewer Permit

PART 1 – Legal Property Owner Information

Name: _____ Phone Number: _____

E-mail: _____

Mailing Address: _____

City: _____ State: _____ Zip: _____

Check if Legal Property Owner is the Permit Applicant. Otherwise, complete Part 2

PART 2 – Authorized Applicant Information (if not Legal Property Owner above)

Name: _____ Phone Number: _____

Business Name: _____

E-mail: _____

Mailing Address: _____

City: _____ State: _____ Zip: _____

PART 3 - Project Site Information

Tax Parcel Number: _____ Sudden Valley Division: _____ Lot(s): _____

Street Address: _____

City: _____ State: _____ Zip: _____

PART 4 - Type of Permit (check all that apply)

Water Service

Single Family Residence

Accessory Dwelling Unit Commercial or Other Type of Building. Describe: _____

Customer Pressure Reducing Valve will be Installed.

Water Supply Fixture Units (WSFU) per Uniform Plumbing Code: _____

Special plumbing or activities that will be present on this site: None

Underground sprinkler system

Water treatment system (e.g. water softener)

Solar heating system

Residential fire sprinkler system

Sewage pumping facility or grey water system

Home-based business. Description: _____

Radiant In-floor Heat

Boiler

Swimming pool or spa

Other water supply

Boat moorage with water supply

(e.g. beauty salon, machine shop, etc...)

DCVA (double check valve assembly) required. This field to be completed by District engineering staff. DCVA requirements are subject to current and future Cross Connection Control Program Requirements.

Sewer Service

Single Family Residence

Accessory Dwelling Unit

List Bonded Side Sewer Contractor Installing Sewer: _____

Gravity Side Sewer

Private Grinder Pump to Gravity Sewer Main (Submit Grinder Pump Service Checklist before construction)

Private Grinder Pump to Sewer Force Main (Submit Grinder Pump Service Checklist before construction)

LAKE WHATCOM WATER AND SEWER DISTRICT

Application for Water/Sewer Permit

PART 5 – County Permits & Water/Sewer Service Site Plan

- Copy of Whatcom County Building Permit**
- Copy of Whatcom County Revocable Encroachment Permit** (required if work is in County Right-of-Way)
- Site Plan.** Plan must be to scale, neat, legible, and include the following information as applicable:

Existing Features. Property lines, buildings, driveways, ditches, culverts, sewer mains, manholes, sewer cleanouts, fire hydrants, water main valves, sewer cleanouts.

Proposed Features. Buildings, driveways, sewer service alignment, cleanouts, connection to sewer main, grinder pump, location of customer pressure reducing valve, easements, backflow preventer.

Note: Tree removal for sewer and water service lines must be coordinated with Whatcom County and/or Sudden Valley Community Association for lots within Sudden Valley.

PART 6 – Permit Conditions

Billing. Water and sewer billing both begin on the date the water meter is turned on by the District. For sewer-only customers, billing begins on the date connection is made to the sewer main. The water meter will only be turned on when the District's Cross Connection Control Program requirements are met; typically by installation of a double check valve assembly at the property line, or by submittal of a copy of the property's Whatcom County Building Inspection Permit indicating final sign-off of the rough plumbing system for verification by the District's Cross Connection Control Program Manager (crossconnection@lwbsd.org).

Construction Standards. Water and sewer services shall be installed per the District's current Design and Construction Standards. Copies of the standards are available at the District office or online at lwbsd.org/building-permitting/design-and-construction-standards/.

Administrative Code and Non-conforming Work. Water and sewer permits are administered in accordance with the District's current Administrative Code available online at lwbsd.org/about-us/administrative-information/. The property owner is responsible for promptly correcting non-conforming work and subject to additional fees, penalties, and expenses as defined in the Administrative Code.

Water Service Installation

- The District will set a meter adjacent to the property line within the public right-of-way or easement corridor at a location determined by the District. If required, the District will install a new service line from the public water main to the meter location. Lot clearing and rough grading must be completed prior to the District installing a service and meter. A water service and meter is typically installed within 2 (two) weeks from the date of request for water service.
- The property owner is responsible for installing a private water service line from the meter to the building. Properties not adjacent to the public water main, such as those located beyond the end of the main or behind lots fronting the main, will require a longer private water service line installed by property owner or potentially be required to extend the public water main past and through their lot as determined by the District.
- All customers are required to install a Pressure reducing Valve (PRV) on the meter side of the service to protect their plumbing systems from high pressure surges. A PRV inspection is required prior to turning the water meter on.
- Water during construction, if requested by the property owner, is subject to the following requirements and conditions to turn on meter:
 1. A Washington State Department of Health-approved double check valve assembly (DCVA) is installed a minimum of 12-inches below grade in a box near the property line just beyond the private pressure reducing valve (PRV) in accordance with the District's Design and Construction Standards.
 2. Installed DCVA must be tested by a certified backflow assembly tester and the test report submitted to the District's Cross Connection Control Program Manager (crossconnection@lwbsd.org).
- A fully installed private water service line from the meter to the building is considered District-approved when installed in accordance with the District's Design & Construction Standards, complies with the above requirements and has no outstanding permit fees and charges.

Sewer Service Installation

- Sewer service lines from the public sewer main to the cleanout adjacent to the building must be installed by a contractor on the District's Bonded Side Sewer Contractor list. A current list of bonded side sewer contractors is available at the District office and online at lwbsd.org/building-permitting/bonded-contractors/.
- Multiple inspections are required prior to occupancy. The owner is responsible for requesting the inspections by contacting the District office (360-734-9224) and scheduling the preconstruction meeting and inspections. The

LAKE WHATCOM WATER AND SEWER DISTRICT
Application for Water/Sewer Permit

owner, or the owner's contractor, may request inspections. A re-inspection fee (per current Master Fees and Charges) will be charged to the account for a no-show preconstruction meeting or re-inspection of deficient work. Required inspections are:

1. Onsite Preconstruction Meeting
 2. Pipe bedding and backfill inspection prior to covering any pipe
 3. Leak test inspection after pipes are backfilled
 4. Grinder pump inspection and station start-up and testing (if applicable and allowed by the District)
- A fully installed sewer service line and grinder pump system, if applicable, is considered District-approved when installed in accordance with the District's Design & Construction Standards, complies with the above requirements and has no outstanding permit fees and charges.

Permit Expiration. Property owners issued connection permits shall have 365 days from the date of issuance of said connection permit to make a District-approved connection to the District water and/or sewer system without being subject to any increase or additional fees in the connection charge. After 365 days have elapsed, the connection permit shall be subject to any increase or additional fees in the connection charge adopted subsequent to the date of issuance of the permit.

The property owner or authorized agent attests that the submitted information is true and correct, and agrees to comply with PART 6 - Permit Conditions listed above.

Application Submitted By: _____ Date: _____
(signature)

Print Name: _____



LAKE WHATCOM WATER AND SEWER DISTRICT

1220 Lakeway Drive
Bellingham, WA 98229
360-734-9224

Re: Water and Sewer Service Installation & Side Sewer Inspection Scheduling

Whatcom County's Lake Whatcom watershed land disturbance window is June 1 through September 30 for projects that disturb more than 500 square feet of ground surface. In past years, there was a surge of activity in late September for side sewer installations performed by District-approved bonded side sewer contractors and water services installed by District staff. The number of inspection and water service installation requests exceeded the District's resources to complete them all before the October 1 land disturbance closure.

The District recommends owners and developers plan ahead and obtain a Water/Sewer Permit as soon as possible, well in advance of the October 1 watershed land disturbance closure. **The District will prioritize water service installations in the order permits are issued (i.e., first come, first served basis).** The District will not be able to install water services that require more than 500 square feet of land disturbance after October 1.

Likewise, bonded side sewer contractors installing sewer services are encouraged to complete this work, with the required District inspections, as early as possible. **District inspection time slots fill up quickly for the last two weeks of September.** Please plan ahead to get your side sewer installed, inspected, and approved early to avoid delays into October.

Sincerely,

Lake Whatcom Water and Sewer District

Justin Clary, PE
General Manager



Lake Whatcom Water and Sewer District Connection Fee Components and Charges

Effective January 1, 2025

(subject to changes by Board of Commissioners and scheduled annual increases)

	Unit Price	Quantity	Amount
Water Connection Fee Components and Charges			
Water General Facilities Fee (5/8"x3/4" Water Meter)	\$ 8,228.50	1	\$ 8,228.50
Installation by District	\$ 2,000.00	1	\$ 2,000.00
Permit Administration & Processing	\$ 170.00	1	\$ 170.00
Initial Water Pressure Reducing Valve Inspection and Documentation	\$ 50.00	1	\$ 50.00
Subtotal Water Connection Charge			\$ 10,448.50
Potential Other Water Fees or Charges			
Water Pressure Reducing Valve Reinspection	\$ 100.00	0	\$ -
COB Reservoir Reimbursement Fee <i>New connections to Eagleridge water system</i>	\$ 300.00	0	\$ -
South Geneva Latecomer Fee <i>Expires 7/22/2026</i>			
Class A	\$ 17,088.97	0	\$ -
Class B	\$ 5,981.14	0	\$ -
Subtotal Additional Fees or Charges			\$ -
Potential Credits			
Pre-Paid Connection Certificate (\$ varies)	\$ -	0	\$ -
Previous Paid Expired Permit (\$ varies)	\$ -	0	\$ -
Subtotal Credits			\$ -

Subtotal Water Connection Fees and Charges \$ 10,448.50

Sewer Connection Fee Components and Charges			
Sewer General Facilities Fee (5/8"x3/4" Water Meter)	\$ 12,538.16	1	\$ 12,538.16
Permit Processing	\$ 170.00	1	\$ 170.00
Initial Sewer Inspection / Grinder Pump Intallation Inspection	\$ 370.00	1	\$ 370.00
Subtotal Sewer Connection Charge			\$ 13,078.16
Potential Other Sewer Fees or Charges			
Scheduled Sewer Inspection - Construction Not Ready	\$ 100.00	0	\$ -
Sewer Reinspection of Deficient Work	\$ 500.00	0	\$ -
District Installed Stub <i>Applies to some lots in Sudden Valley where District installed a sewer lateral from the sewer main to the property line.</i>	\$ 755.00	0	\$ -
Lakewood/Grand Blvd Special Benefit Fee <i>Applies to lots where District extended public sewer main to serve defined group of lots.</i>	\$ 6,000.00	0	\$ -
ULID 18 Charges In-Lieu of Assessment <i>Increases 9.5% annually every January 1, expires January 30, 2028. Applies to properties which are not subject to ULID 18 Assessment, but are located within the South Shore Service Area benefitting from the Lake Louise Road Interceptor.</i>	\$ 9,759.57	0	\$ -
South Geneva Latecomer <i>Expires 7/22/2026</i>			
Class A	\$ 22,406.50	0	\$ -
Class B	\$ 1,704.55	0	\$ -
Subtotal Additional Fees or Charges			\$ -
Potential Credits			
Pre-Paid Connection Certificate (\$ varies)	\$ -	0	\$ -
Previous Paid Expired Permit (\$ varies)	\$ -	0	\$ -
Subtotal Credits			\$ -

Subtotal Sewer Connection Fees and Charges \$ 13,078.16

Total Water and Sewer Connection Fees and Charges \$ 23,526.66

MEETING DATE: _____

BY: _____



PRECONSTRUCTION MEETING

PROPERTY ADDRESS: _____ DIVISION: _____ LOT: _____

CONTRACTOR: _____
(ONLY DISTRICT BONDED AND APPROVED SIDE SEWER CONTRACTORS PERMITTED)

PRECONSTRUCTION MEETING ATTENDEES: _____

DISCUSSION ITEM CHECKLIST

SEWER CONNECTION – ONE OPTION APPLIES AS DIRECTED BY DISTRICT

- SEWER CONNECTION TO EXISTING SHARED LATERAL: Location _____
- SEWER CONNECTION TO EXISTING SEWER MAIN TEE: Location _____
(IF A SEWER TEE OR LATERAL IS NOT FOUND IN LOCATION GIVEN, CONTRACTOR SHALL PROSPECT 2 FEET IN ALL DIRECTIONS FROM THE MEASUREMENT GIVEN. NOTIFY DISTRICT PER ADMIN CODE 5.4.5-2)
- NEW 6" CORE DRILL SERVICE SADDLE ON 8" MAIN: Location _____
- NEW 4" CORE DRILL SERVICE SADDLE ON 6" MAIN: Location _____
- SEWER CONNECTION TO EXISTING MANHOLE: Location _____
(CORE DRILL INTO BENCH AND KOR-N-SEAL BOOT REQUIRED, INSIDE DROP NOT PERMITTED)
- INSTALL 6" SEWER CLEANOUT AT PROPERTY LINE, W/ THREADED CAP AND BROUGHT TO GRADE (DETAIL S7)
- ADD WYE FOR ADJACENT PROPERTY IF LATERAL CAN BE SHARED IN FUTURE
- CALL OFFICE 2 BUSINESS DAYS IN ADVANCE FOR SEWER INSPECTION (OFFICE PHONE IS 360-734-9224)
- SEWER IS READY FOR FIRST INSPECTION WHEN:
 - TRENCH/EXCAVATION IS IN COMPLIANCE WITH WISHA SAFETY STANDARDS
 - PIPE IS BEDDED WITH TOP OF PIPE EXPOSED
 - GREEN TRACER WIRE ON ALL PIPE (WRAP END SECURELY AROUND CLEANOUTS BROUGHT TO GRADE)
- SEWER IS READY FOR SECOND INSPECTION WHEN:
 - BACKFILL IS WITHIN ONE FOOT OF FINISH GRADE AND LOCATE TAPE IS INSTALLED
 - PIPE IS FILLED WITH WATER FOR WATER TEST
- CALL OFFICE IF SCHEDULE CHANGES
- A \$500 FEE IS CHARGED FOR RE-INSPECTIONS OR A \$100 FEE IF CONTRACTOR IS NOT READY FOR INSPECTION AT SCHEDULED TIME.
- WATER SERVICE CONNECTION – WILL NEED A 3/4" FIP ADAPTER TO CONNECT TO BRASS NIPPLE
- PRV MUST BE INSTALLED WITHIN 5' OF METER BOX BEFORE WATER CAN BE TURNED ON

NOTES: _____

INITIAL / DATE _____
DISTRICT REPRESENTATIVE

INITIAL / DATE _____
CONTRACTOR

LAKE WHATCOM WATER AND SEWER DISTRICT Grinder Pump Service Checklist

DESIGN/PUMP SELECTION

Grinder Pump System

Tax Parcel Number: _____

- E-One D Series Package Grinder Pump System
 Other (System must be reviewed and approved by District. Submit drawings, specifications, & calculations)

Static Head (feet): _____ (Vertical distance, or height, effluent is pumped)

Dynamic Head (feet): _____ (Friction losses due to pipe, bends, valves, fittings)

Total Dynamic Head (feet): _____ (Static Head + Dynamic Head)

Pump Operating Point (gpm): _____ (Flow rate of pump at Total Dynamic Head)

MINIMUM SPECIFICATIONS

Grinder pump systems shall be in accordance with Section C1-10.1 and C1-10.2 of the current edition of the Criteria for Sewage Works Design published by Washington State Department of Ecology. Specific section references from the design manual are noted in parentheses below.

Installed grinder pump system shall meet the criteria for the maximum hydraulic gradeline and be able to meet the pumping requirements of the structure where it is installed. (C1-10.1.5)

Connection to Gravity Sewer Main

- Pressure service line shall be 1-1/4" HDPE SDR11 between grinder pump and gravity sewer stub.
 Minimum pipeline velocity of 2 feet per second. (C1-10.1.4)
 Maintenance shut-off ball valve on discharge line at grinder pump. (C1-10.2.1A)
 One check valve required. Can be installed on grinder pump. (C1-10-2.1A)

Connection to Force Main

- Pressure service line shall be 1-1/4" HDPE SDR11 between grinder pump and check valve vault.
 Minimum pipeline velocity of 2 feet per second. (C1-10.1.4)
 Maintenance shut-off ball valve on discharge line at grinder pump.

Two check valves required. (C1-10.2.1A)

- Check valve #1: Installed at Grinder Pump. Can be installed on grinder pump.
 Check valve #2: Installed at property line. Check valve in vault per Standard Detail S16.
 Tapping saddle, 2" corp stop, resilient seat gate valve, and valve box at force main. (C1-10.2.1A)
 2" HDPE SDR11 service line between forcemain and check valve vault.

Control Panel / Electrical Requirements

- Grinder pump UL Listed for use in raw sewage. (C1-10.2.2A)
 Pump control panel and level-sensing mechanism UL Listed for use in raw sewage (C1-10.2.2C)
 High level visual and audio alarm with battery backup. (C1-10.2.2C)
 Audio alarm capable of being silenced until repair can be made. (C1-10.2.2C)
- Power transfer switch with an emergency generator plug for vessels with less than 24 hours of storage (1000 gallons for single family residence). (C1-10.1.6D&E)
- Electrical components in compliance with National Electrical Code and state Labor and Industries Electrical Inspection Division. (C1-10.2.2D)

Ventilation

- Grinder pump storage tank shall have a separate vent system from structure plumbing. (C1-10.2.2E)

DESIGNER/SUPPLIER CONTACT INFORMATION

Designer: _____ Phone: _____ Date: _____
 (print name)

Supplier: _____ Phone: _____ Date: _____
 (print name)



WATER AVAILABILITY FORM
PUBLIC WATER SYSTEM

WHATCOM COUNTY HEALTH DEPARTMENT
509 Girard Street
Bellingham, WA 98225
Telephone: 360-778-6000
Fax: 360-778-6001

Complete and submit form with original signatures to WCHD

Applicant Information:

Applicant/Owner(s): Phone:
Address: City: State: Zip:
Contact Person: Phone:
Email and/or Alternate Contact:

I certify that I am the owner or authorized representative of the below noted property. I have examined this form and know the same to be true and correct. I understand that this approval expires one year after the PWS Authorized Representative signature date and that application for final plat approval and/or building permit must be made before the expiration date. I understand that information submitted is subject to the Public Records Act.

Sign: Print: Date:

Property Information: Project Type: Single Multi-Family ADU Commercial Plat

Tax Parcel Number (twelve digit number):

Address of Project:

Building Permit Number: Plat Name: Lot:

Briefly describe project (attach site plan and additional pages as needed)

Certification of Public Water Availability: to be Completed by the PWS Authorized Representative

Group B water systems must have current water tests - bacteriological less than one year old and nitrate less than three years old.

Public Water System Name: DOH ID#:

The above Public Water System (PWS) is approved by the WA State Department of Health or the WCHD for service connections and currently serves service connections. The PWS has the necessary water system infrastructure in place to adequately provide service to the above property per WAC 246-290 or WAC 246-291. The PWS is capable of and willing to supply water to the above property, residence, project or plat for New service(s) and/or Existing service(s).

Direct Connection? Yes No (meter ready, no extension required)

Conditions of Service

I certify that I am an authorized representative of the above PWS. I understand this certification expires one year after the PWS signature date. I understand that information submitted is subject to the Public Records Act 42.56.

Sign: Print: Date:

Title: Address: Phone:

For Health Department Use Only:

Approved Date: Approval Expires:

Denied

By: Well Constructed After January 2018: Yes No

Comments or Conditions:

Notify Via: Email Phone Mail

The subdivision/building permit is located in an area that is governed by chapter 173-501 WAC and in which instream flows are not met and/or are subject to closure. In compliance with ch 58.17 RCW/RCW 19.27.097 the County has determined adequate potable water is available for this subdivision/building permit on the basis of evidence supplied by the Applicant. Other authorities, including courts of competent jurisdiction and the Department of Ecology, exercise jurisdiction over water resources in the state of Washington. Those authorities may determine that the proposed source of water for this project identified by the Applicant is not a valid water right appropriation or is subject to curtailment or seasonal restrictions on availability that could impact its reliability for the intended use. The County's issuance of this subdivision/building permit should not be relied upon by the Applicant or any successor in interest as an assurance, warranty or guarantee of the future availability of water to serve the subdivision/building permit.

Intake
Entry
Notify



LAKE WHATCOM WATER & SEWER DISTRICT

1220 Lakeway Drive
Bellingham, WA, 98229

(360) 734-9224
Fax 738-8250

{Date}

Re: Sewer "Will Serve" Letter for
{Address}
{Assessor Parcel Number}

To Whom It May Concern:

The District can currently provide sewer service to the above parcel. Currently water is not available to this parcel. Prior to issuance of a sewer permit, a Covenant Binding Property Regarding Future Water Service must be recorded at the Whatcom County Auditor's Office. See attached covenant form.

This determination, however, is not indefinite, nor irrevocable. Nothing stated herein constitutes a commitment to provide water and sewer service to you in the future. The information used to arrive at this determination of availability is believed to be accurate at this time, but future demands are not always predictable. Similarly, new laws, regulations, or ordinances could also limit the ability to provide water and sewer service in the future. Accordingly, any expenditure which you make in anticipation of future sewer service is strictly at your own risk. Any statements in paragraph(s) above which are inconsistent with this paragraph should be disregarded.

Please call if you have any questions.

Sincerely,

LAKE WHATCOM WATER & SEWER DISTRICT

{District Representative}
{Title}

*** FOR INFORMATIONAL PURPOSES ONLY ***
DISTRICT STAFF WILL COMPLETE THIS CHECKLIST

Assessor Parcel Number: _____

Address (if known): _____

Water/Sewer Permit and Construction Checklist

➤ **Additional fees and credits associated with property**

ULID #18 – is property located within the south shore sewer service area?

- NO**, then ULID 18 does not apply.
- YES**, then check if property **has Restrictive Covenant?**
 - YES**, then property cannot be served by sewer. *Owner might be able to trade restriction for assessment from another property.*
 - NO**, then property can be served by sewer.

Has ULID 18 assessment?

- YES**, then can be served with no additional fees.
- NO**, then Charges-in-Lieu of Assessment apply.

Charges-in Lieu of Assessment: \$ _____
for Year _____.

Is property located in a Latecomer Area?

- NO**, then no additional fees apply
- YES**, then following Latecomer Fees apply:

	\$ _____
	\$ _____
	\$ _____

District installed Sewer Stub?

- NO**, then no additional fees apply
- YES**, then an additional charge applies.

\$ _____

Applicable credits?

- Pre-Paid Connection Certificate
- Expired Permit(s)

Credit: \$ _____

Credit: \$ _____

*** FOR INFORMATIONAL PURPOSES ONLY ***
DISTRICT STAFF WILL COMPLETE THIS CHECKLIST

➤ **Water Availability Form, Water/Sewer Availability Form, or Sewer-Only Will-Serve Letter**

Property is located within Urban Growth Area (UGA) or Local Area of More Intense Rural Development (LAMIRD)?

- NO**, then City of Bellingham must confirm lot existed prior to May 1, 2005 in accordance with the Interlocal Agreement for Sewage Services between the City and District prior to District issuing an availability for sewer.

Process for confirmation with City of Bellingham.

- Property owner provides District with copy of deed or Whatcom County Lot of Record determination that proves lot existed prior to May 1, 2005.
 - District will send information to City for confirmation
 - When District receives confirmation from City that lot can be served, District can continue with sewer availability checklist.
- YES**, then continue to next checklist item.

Conditions for water and/or sewer availability.

Property is adjacent to water and sewer?

- YES**, then prepare Water and Sewer Availability Form
- NO**, then check next condition

Property is adjacent to Sewer only?

- YES**, then Covenant Regarding Future Water Service is required prior to Sewer-Only Will-Serve Letter, or if within 200-Feet of Water System, Developer Extension may be required.
- NO**, then check next condition

Property is adjacent to Water only?

- YES**, then Covenant Regarding Future Sewer Services is required prior to Water Availability Form, or if within 200-Feet of Sewer Main, Developer Extension may be required (if located within LAMIRD or UGA).

➤ **Submit & Sign Application for Water/Sewer Permit forms to District. Include the following:**

- Copy of Whatcom County Building Permit
- Copy of Whatcom County Revocable Encroachment Permit (Required if work is in County Right-of-Way)
- Site Plan to include Existing and Proposed Features
- Special Plumbing or Activities to be listed
- Submit Grinder Pump Checklist if required
- Designate Bonded Side Sewer Contractor performing side sewer installation

➤ **Pay Connection Fees**

- District will prepare Water/Sewer Permit and call to schedule time for payment and pickup (typically 1 business day after submittal of Application for Water/Sewer Permit).

*** FOR INFORMATIONAL PURPOSES ONLY ***
DISTRICT STAFF WILL COMPLETE THIS CHECKLIST

➤ **Connection to Sewer**

- Contractor requests a pre-construction meeting with District prior to any work.
- Installation of the side sewer from the public sewer main to the house must be performed by a contractor on the District's Bonded Side Sewer Contractor List.
- Contractor requests sewer pipe bedding and backfill inspection prior to covering any pipe.
- Contractor requests sewer leak test Inspection
- Billing for sewer-only customers begins the date the side sewer is connected to the public sewer main.

➤ **Connection to Water**

- Upon customer request, and after proposed lot clearing and rough grading is complete, District will install water meter adjacent to property. Typically within 2 weeks.
- Customers install their own water service lines from the water meter to the house per District standards.
- Customer requests inspection of private pressure reducing valve required (PRV) on the service line per Standard Detail W11. The PRV protects internal plumbing from pressure spikes in public water system. The District's distribution system has over 50 large PRV's located throughout the system. These large PRV's have the potential to stick open and cause high water pressure with no warning. Customers may elect not to install a private pressure reducing valve after recording a Hold Harmless Agreement Concerning Owner's Desire Not to Install a Pressure Reducing Valve.
- Customer submits Whatcom County Building Inspection Permit indicating final sign-off of rough plumbing for verification by the District's Cross Connection Control Program Manager **OR** double check valve assembly (DCVA) is installed per District Standard W13.
- Billing for both water and sewer (if also served by sewer) begins the date the water meter is unlocked by the District at customer's request.

GENERAL NOTES

1. All work and materials shall meet the requirements of the most current editions of the Lake Whatcom Water and Sewer District (District) Design and Construction Standards, Lake Whatcom Water and Sewer District Construction Contract Documents and Project Specifications (for Public Works Projects), the instructions and recommendations of the Manufacturer of the material concerned and select specifications within the Standard Specifications for Road, Bridge and Municipal Construction as prepared by Washington State Department of Transportation (WSDOT) and with all other regulatory agency requirements and permits including but not limited to work within Whatcom County right-of-way shall meet Whatcom County (County) design and construction requirements. In case of a conflict between the above standards, the more stringent shall apply. All work and materials shall be subject to the approval of the District Engineer.
2. Contractor shall obtain encroachment permits or other permissions which may be required from the County, Sudden Valley Community Association, or other entity having jurisdiction over roads and streets, prior to commencing work.
3. Contractor shall provide and maintain all Temporary Erosion Control and Sedimentation (TESC) in accordance with the most current edition of the Storm Water Management Manual for Western Washington (SWMMWW), Volume II, by the Washington State Department of Ecology, Publication Number 14-10-055. Contractor shall use required and necessary Best Management Practices (BMPS) described therein and as may be further described or detailed on the project drawings.
4. Contractor shall call 1-800-424-5555 48 hours before construction for utility locations. Contractor shall not begin excavation until utility notification period is complete.
5. A preconstruction meeting is required with the District and Contractor performing the work a minimum of 2-days before the start of construction.
6. Authority of Engineer, its appointees, assistants and inspectors, shall be per WSDOT 1-05.1. All references to the Engineer or District Engineer shall also mean its appointees, assistants and inspectors as per WSDOT 1-05.2.
7. The Contractor shall be responsible for the safety of all workers and shall comply with all appropriate state safety and health standards, codes, rules, and regulations, including, but not limited to, those promulgated under the Washington Industry Safety and Health Act RCW 49.17 (WISHA) and as set forth in Title 296 WAC (Department of Labor and Industries). In particular the Contractor's attention is drawn to the requirements of WAC 296.800 which requires employers to provide a safe and healthful workplace.
8. Inspection of work and materials shall be in accordance with WSDOT 1-05.6. Removal of unauthorized or defective work shall be in accordance with WSDOT 1-05.7.
9. The Contractor shall take all steps necessary to ensure that the existing facilities remain fully operational during all stages of construction, including but not limited to providing bypass pumping, standby storage, emergency generators and pump trucks, as necessary during service interruptions or outages.
10. No inspections or tie-ins to District's facilities shall be performed on a Friday, Weekend or District Holiday.



GENERAL NOTES

STANDARD DETAIL

G1

3/11/2020

11. All pipe shall be bedded in bedding material meeting the requirements of WSDOT 9-03.12(3). The bedding cross-section shall be blocked with Control Density Fill (CDF) per WSDOT 2-09.3(1)E a minimum of every 800 feet and the trench drained to daylight or to a storm drain in accordance with District Standard Detail G11.

12. Backfill above the pipe zone bedding within County ROW and Sudden Valley, within the roadway section or at driveway crossings shall consist of crushed surfacing top course material meeting the requirements of WSDOT 9-03.9(3). Backfill within private driveways shall consist of material meeting the requirements of WSDOT 9-03.19. Backfill in other areas shall consist of material meeting the requirements of WSDOT 9-03.15, except as shown on the plans or details. Backfilling of trenches shall be in accordance with WSDOT 7.08.3(3).

13. Pea gravel shall not be used for pipe bedding or trench/excavation backfill material. The District may approve limited use of pea gravel where hazardous site conditions exist that pose an immediate threat to workers or public. Pea gravel, if approved for use by the Engineer, shall be a clean mixture free from organic matter meeting the following gradation (passing by weight a US standard sieve); 100% passing 1/2", 95-100% passing 3/8", 0-10% passing #8, and 0-3% passing #200.

14. Backfill shall be compacted to minimum 95% modified Proctor within traffic areas and minimum 90% modified Proctor in landscape and open areas.

15. Tracer wire installation is required on all District owned pipe, electrical conduits and communication lines/conduits. Tracer wire is also required on private side sewers. Install tracer wire per District Standard Detail E6. In addition to tracer wire, install 2-inch wide detectable marking tape 8 to 12 inches below the finish surface. Detectable marking tape shall meet the requirements of WSDOT 9-15.18 and be color coded blue for water, green for sewer, red for electrical and orange for telecommunication.

16. Public water lines and any sanitary sewer line or other non-potable conveyance system shall maintain a minimum of 10-foot horizontal separation (parallel alignment) and a minimum 18-inch vertical separation (parallel alignment and crossings at angles including perpendicular with the sewer line below the water line), measured as the closest distance between outside of pipes, in accordance with the most current editions of the Washington State Department of Health (DOH) Water System Design Manual Section 8.4.4 and the Department of Ecology (DOE) "Criteria for Sewage Works Design" Section C1-9.

When local conditions prevent these separations, with the approval of the District Engineer, installations shall follow the requirements outlined for unusual conditions in the referenced DOH and DOE manuals which includes details for specific pipe materials, pipe segment lengths, joint separation requirements, concrete encasement and/or pipe casings. If a pressure sewer cannot be installed with a minimum 18-inch separation from a water line at a crossing, then the pressure sewer shall be constructed only under the water line with ductile iron pipe or standard sewer pipe in a casing (casing material per the DOE manual) extending at least 10-feet on each side of the crossing.

17. Control Density Fill (CDF), if required, shall meet the requirements of WSDOT 2-09.3(1)E.

18. From the main to the property line, sewer pipes and water pipes shall maintain a minimum horizontal separation of 10-feet. When local conditions prevent the 10-foot separation, separation shall be per District Standard Detail G10, Water Line and Sewer Line Trench Detail, Unusual Conditions. Separation of water service lines and sewer pipes within private property shall be per District Standard Detail G9.



19. Contractor shall remove all debris and excess excavation; repair all damage, and restore the site, public or private, to pre-construction conditions.

20. Where mains or service lines are placed within a ditch area, the buried depth shall be at least 30-inches below the bottom of the ditch, measured from the crown of the pipe to the bottom of the ditch.

21. All work within Whatcom County Right Of Way (ROW) shall meet the requirements of the most current edition of the Whatcom County Development Standards, Section 512.

22. The Lake Whatcom Water and Sewer District is located within the Lake Whatcom Watershed where seasonal clearing activity limitations established by Whatcom County Code 20.51.410 are in force. Clearing activity, which includes trench excavation/backfill and other land disturbance, that will result in exposed soils exceeding 500 square feet are not permitted from October 1 through May 31.

23. References to the Uniform Plumbing Code (UPC) shall be to the edition, amendments standards and exemptions adopted by Whatcom County, as detailed in the most current edition of the Whatcom County Code, Chapter 15.04, Building Codes.



GENERAL NOTES

STANDARD DETAIL

G3

3/11/2020

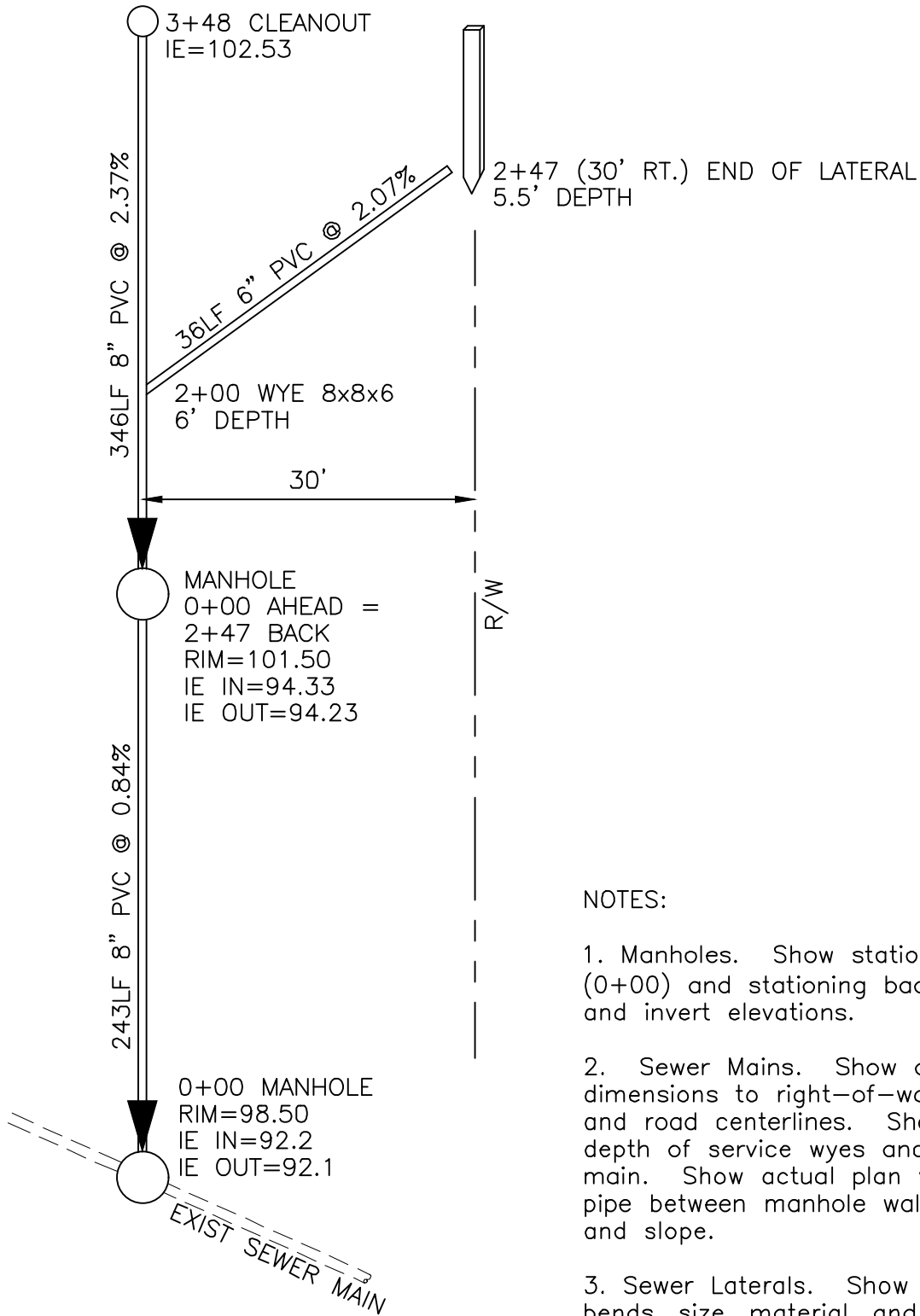

EXAMPLE RECORD DRAWING

NOTES:

1. Manholes. Show stationing ahead (0+00) and stationing back, rim elevation, and invert elevations.

2. Sewer Mains. Show alignment dimensions to right-of-way, easements, and road centerlines. Show station and depth of service wyes and tees along the main. Show actual plan view length of pipe between manhole walls with material and slope.

3. Sewer Laterals. Show distances between bends, size, material, and length of pipe. Show station, offset, and depth at end of stub or cleanout.



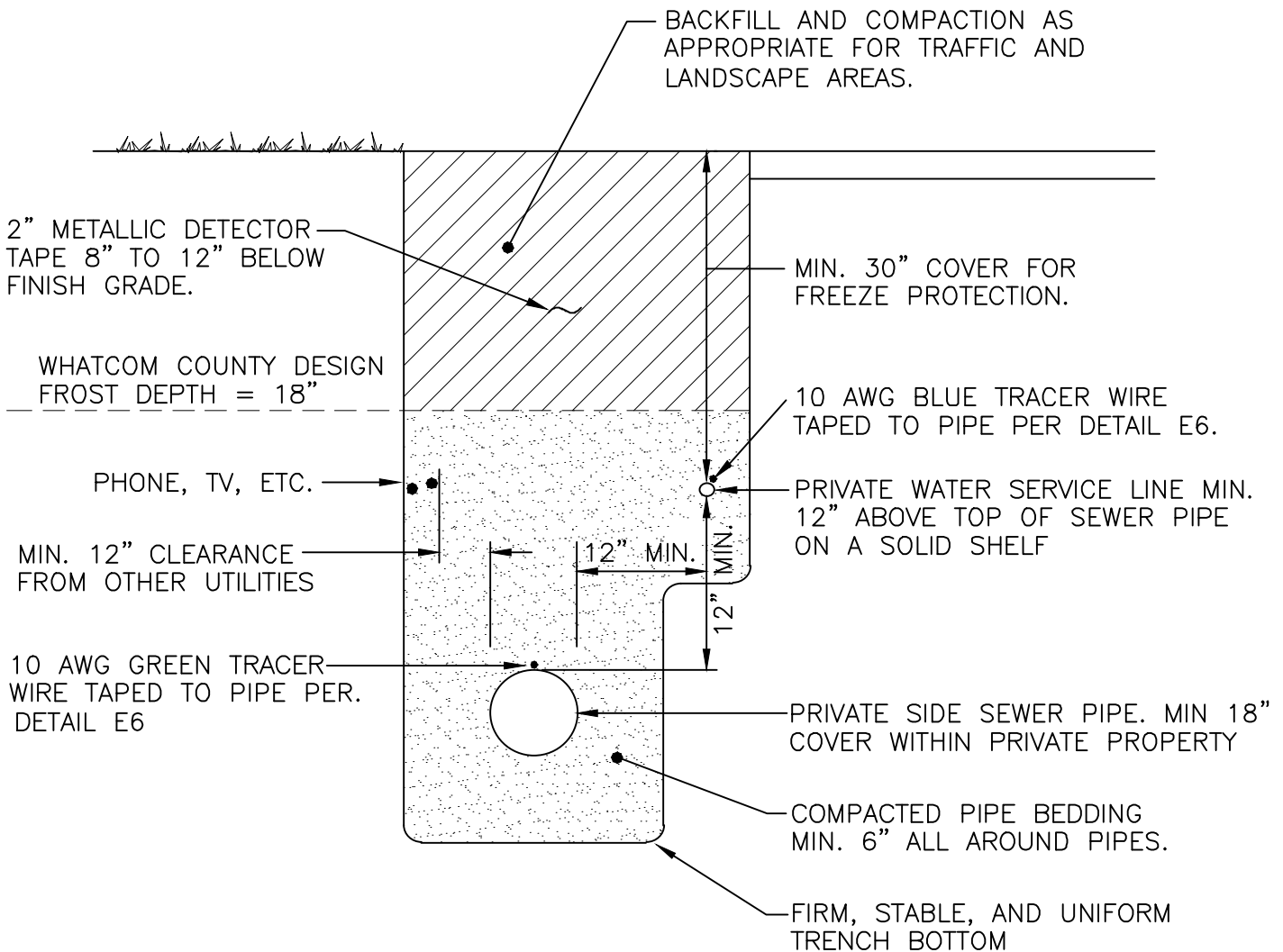

NOTES:

1. Side sewer lines and water service lines shall not be installed in the same trench unless the above common trench detail is adhered to (UPC 720.1).
2. Water service lines crossing a sewer line shall be a minimum of 12-inches above the top of the sewer line (UPC 720.1(3)).
3. When a common trench is used for water service and side sewer lines, both pipes shall be bedded in material meeting WSDOT 9-03.12(3) Gravel Backfill for Pipe Zone Bedding as shown in following table:

Sieve Size	Percent Passing by Weight
1.5"	99-100
1"	75-100
5/8"	50-100
U.S. No. 4	20-80
U.S. No. 40	3-24
U.S. No 200	10.0 max
Sand Equivalent	35 min.



COMMON TRENCH DETAIL: PRIVATE WATER SERVICE LINE AND SIDE SEWER LINE

STANDARD DETAIL

G8

3/11/2020

WATER SYSTEM NOTES

1. Water distribution system materials, trenching, bedding, installation, backfilling, disinfection, and testing shall meet the requirements of WSDOT 7-09.
2. All water piping and appurtenances in contact with potable water shall be certified under NSF-61 for potable water use in accordance with WAC 246-290-220.
3. Water main pipe shall be class 52 ductile iron per WSDOT 9-30.1(1) and encased in polyethylene encasement per WSDOT 9-30.1(2). Fittings for ductile iron pipe shall meet the requirements of WSDOT 9-30.2 (1).
4. Water Main Appurtenances. Valves shall have a minimum pressure rating of 200 psi. Gate valve installation shall conform to WSDOT 7-12. Gate valves shall be resilient-seated gate valves conforming to WSDOT 9-30.3(1) and AWWA C515 Standard for Resilient Seated Gate Valves. A cast iron valve box with a commercial concrete collar (18" x 18" x 6") shall be installed with each valve. An approved marking post shall be installed with each valve in accordance with WSDOT 7-12.3(1) for all valves not installed in pavement. Valves not in pavement shall have a 24" x 24" x 6" concrete collar cast around the valve box. Where a valve operating nut is more than 4-feet lower than grade, an American Flow Control Trench Adapter valve box and stem extension combination (or approved equal) must be installed.
5. Pressure reducing valves (2" and larger) shall be manufactured by Cla-Val, Watts, or approved alternate.
6. Service connections shall be installed per WSDOT 7-15. Lot corners shall be staked prior to service connection installations to assure services are installed in correct locations as shown on the approved plans.
7. The District Engineer shall witness pressure testing. Bacteriological sampling shall be conducted by a District certified operator (employee). Contractor shall provide the District Engineer 48-hours notice prior to conducting tests or sampling.
8. Water lines and appurtenances shall be pressure tested in accordance with WSDOT 7-09.3(23).
9. Before being placed into service, new water mains and repaired portions of, or extensions to, existing mains shall be flushed and disinfected by the Contractor in accordance with WSDOT 7-09.3(24) and the most current edition of the American Water Works Association (AWWA) Standard C651, Disinfecting Water Mains. As stated therein, the District requires two set of samples, either a) taken 16 hours apart or b) two samples are taken 15 minutes apart after a 16 hour rest period, satisfactorily passing bacteriological testing requirements (testing includes but is not limited to testing for total coliforms, fecal coliforms and E.coli found in the water sample) meeting current Washington State Department of Health (DOH) Standards, before connecting the new or repaired portion of main. Costs of bacteriological testing shall be borne by the Contractor. In addition, Contractor shall provide two chlorine concentration test reports to show the initial chlorine concentration is at least 50 mg/L, and to show the 24-hour residual chlorine concentration is at least 25 mg/L. All tests must be performed by a DOH-certified testing laboratory and sample-taking shall be performed by a District certified operator (employee). Bacteriological samples must be collected by the District. Chlorinated flush water must be dechlorinated and disposed of in accordance with WSDOT 7-09.3(24)A. If disposal is to the District's sanitary sewer system, Contractor shall coordinate with District staff to ensure



WATER SYSTEM NOTES

STANDARD DETAIL

W1

3/11/2020

the rate of disposal does not overload the District's sewer system.

10. New services shall be pressure tested along with the new main. No use of water through a newly installed service shall be allowed until water main and service installation has been inspected, pressure tested, chlorinated and a satisfactory bacteria test received. After installation, the service connection shall be flushed prior to connecting the meter. No service is to be covered until the District's Inspector has inspected the initial installation. All corporations must be in an ON position and all angle valves must be in the OFF position.

11. Service flow testing shall be done after water main pressure testing. During the inspection, every service shall be turned on to its full capacity to check flow and guarantee that each service line has been flushed.

12. Water service lines on the customer side of the water meter shall meet the requirements of the Uniform Plumbing Code (UPC).

13. In accordance with District Administrative Code Section 4.3.6, all customers are required to install a Pressure Reducing Valve (PRV) downstream of the meter and dual check valve on the customer side of service to protect their plumbing systems from high pressure surges. A PRV inspection by District personnel is required prior to occupancy. See detail W11.

14. In accordance with WAC 246-290-490 and District Resolution No. 858, all cross-connections between the District's water distribution system and a consumer's water system shall be eliminated or controlled by the installation of a District approved backflow preventer commensurate with the degree of hazard. The District's Cross-Connection Control Program is available for review at the District office or on the District website (www.lwwsd.org).





FORD ANGLE VALVE FOR SINGLE SERVICE MODEL KV63-342W-G-NL

MASTER 3G WIRELESS METER

FORD GA13-332-NL ANGLE METER VALVE

METER BOX:
SINGLE - CARSON #1419
DUAL - CARSON #1220

MATCH EXISTING GRADE

DUAL CHECK VALVE
FORD HHC81-333-NL

CUSTOMER SERVICE LINE

10 GAUGE TRACER WIRE WITH SILICONE FILLED WATER RESISTANT NUT(S)

3/4" 90° ELBOW

3/4" FIP (NOT SUPPLIED BY DISTRICT)

200 PSI POLYETHYLENE SERVICE LINE PER WSDOT 9-30.6(3)B

3/4" IP X 12" NPT BRASS NIPPLE

CORP STOP, FORD, GRIP JOINT, NO LEAD. SIZE TO MATCH POLYETHYLENE SDR7 200 PSI PIPE.

ROMAC 101-S SINGLE STRAP SERVICE SADDLE

RIGHT-OF-WAY

LOT LINE
PROPERTY CORNER

DUAL SERVICES INCLUDE FORD U-BRANCH (UV63-42W-G-NL)



NOTES

1. Service fittings shall be in accordance with WSDOT 9-30.6 except that PEX-a-tubing is not allowed and only compression (grip joint) fittings on service lines are allowed. All fittings shall be brass.
2. The water service pipe shall have a minimum of 30 inches depth and a maximum of 36 inches depth, including under ditch sections.
3. Meter boxes in traffic areas shall be rated for H-20 loading with a reader lid.



WATER METER ASSEMBLY

STANDARD DETAIL

W10

4/26/2023

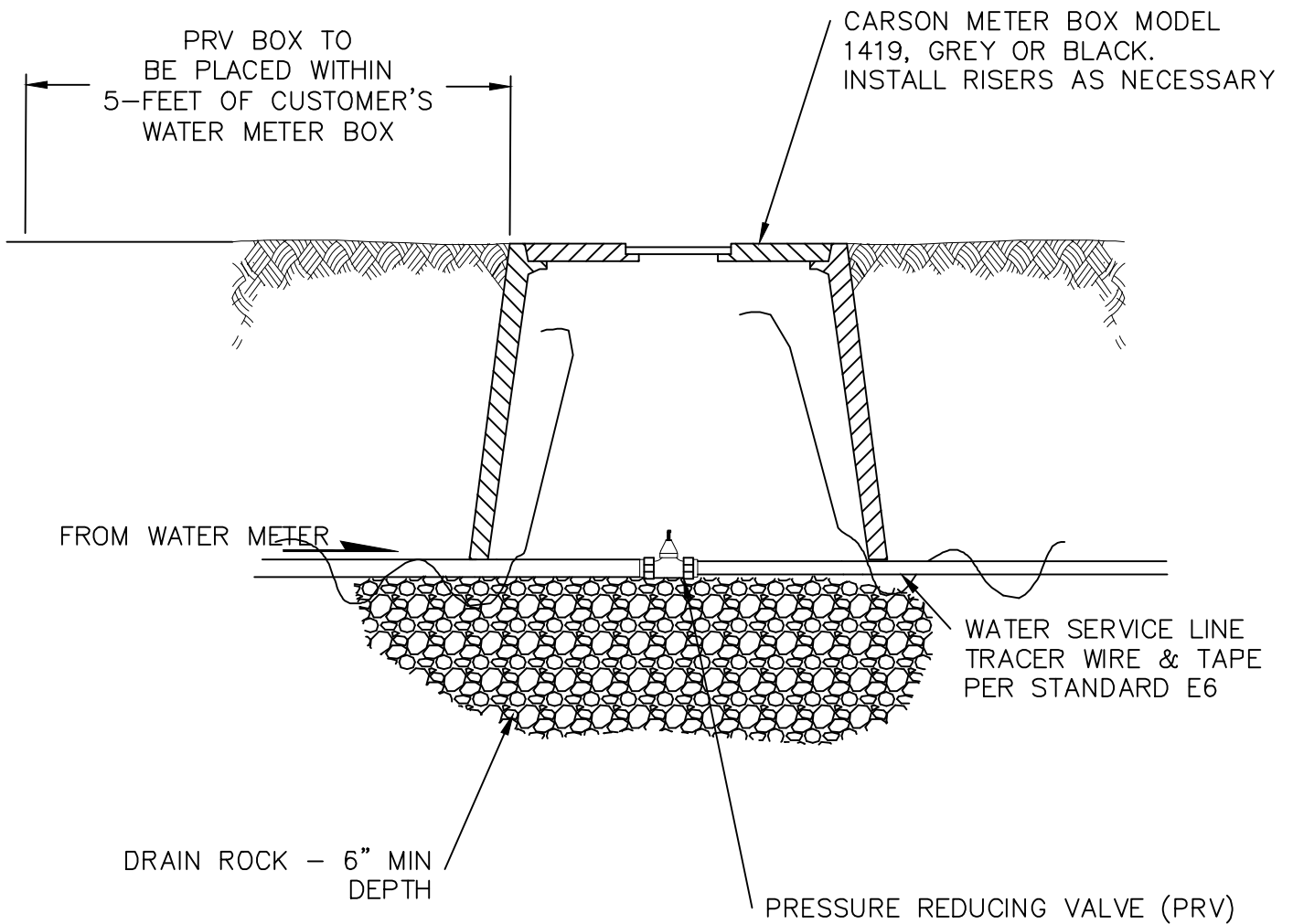

NOTES

1. The pressure reducing valve assembly shall be located on the customer's property downstream of the water meter box assembly.
2. A pressure reducing valve is required for all water service lines.
3. All fittings shall be brass.
4. Installation, maintenance and operation of the pressure reducing valve is the responsibility of the property owner.



PRIVATE SERVICE PRESSURE REDUCING VALVE

STANDARD DETAIL

W11

3/16/2021

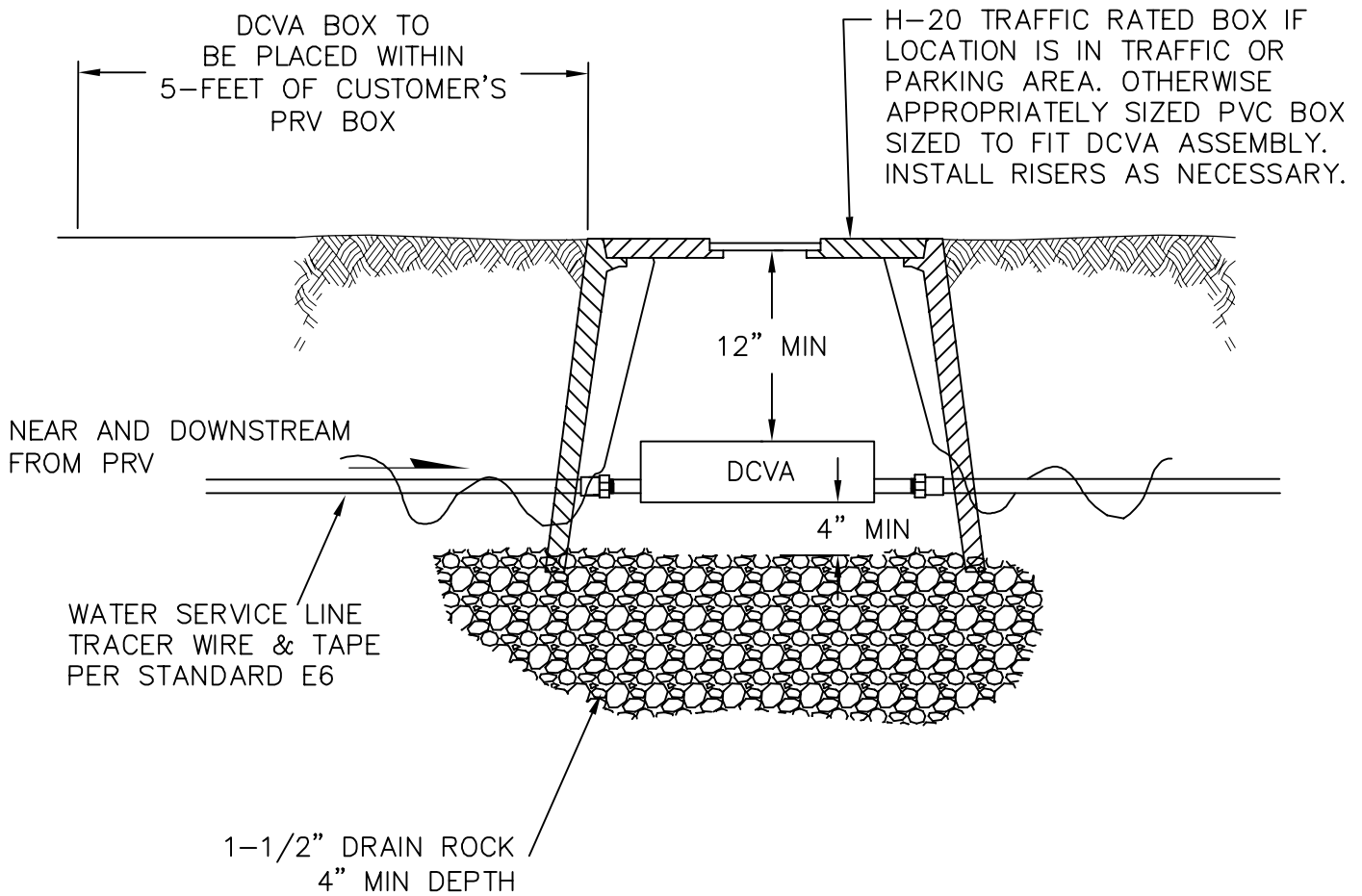

DOUBLE CHECK VALVE ASSEMBLY REQUIREMENTS:

1. In accordance with the District's Cross Connection Control Program, a double check valve assembly shall be installed by the property owner in accordance with this standard detail when plumbing or activity present on the property requires a double check valve assembly.
2. A Washington State Department of Health approved double check valve assembly (DCVA) shall be installed a minimum of 12-inches below grade in a box near the property line just beyond the private pressure reducing valve (PRV).
3. After installation, installed DCVA shall be tested by a certified backflow assembly tester and the test report submitted to the District's Cross Connection Control Program Manager (crossconnection@lwwsd.org).
4. Ongoing testing and reporting is required in accordance with the District's Cross Connection Control Program.



SINGLE FAMILY RESIDENCE
PRIVATE DOUBLE CHECK VALVE ASSEMBLY

STANDARD DETAIL

W13

4/26/2023

SEWER SYSTEM NOTES:

1. Sewer system materials, trenching, bedding, installation, backfilling, and testing shall meet the requirements of WSDOT 7-05 and WSDOT 7-17 and District standards detailed herein.
2. Gravity sewer pipe shall be ASTM D3034-SDR 35 PVC per WSDOT 9-05.12(1). In certain applications, the District may require class 52 ductile iron pipe, per WSDOT 9-30.1(1), encased in polyethylene encasement per WSDOT 9-30.1(2).
3. Pressure sewer pipe shall be class 52 ductile iron pipe per WSDOT 9-30.1(1) encased in polyethylene encasement per WSDOT 9-30.1(2) or PVC C900 class 150 per WSDOT 9-30.1(5). HDPE may be substituted with the approval of the District Engineer (pipe rating, resins, physical properties, dimensions and tolerances must be as specified in the American Water Works Associations (AWWA) Manual C901 for the specific design conditions).
4. Sewer service lines from the public sewer main to the cleanout adjacent to the building must be installed by a contractor on the District's current Bonded Side Sewer Contractor list.
5. All sewer system installations shall be inspected prior to backfill.
6. All gate valves for sewer force mains shall have a cast iron valve box with a commercial concrete collar (18" x 18" x 6") with each valve. Valves not in pavement shall have a 24" x 24" x 6" concrete collar cast around the valve box.
7. Side sewers, from main to private property line, shall meet the requirements of WSDOT 7-18. Side sewers shall have a minimum slope of 2%. Side sewers shall maintain a minimum cover of 36-inches and 30 inches under ditches. Side sewers and cleanout/test tee at property line shall be minimum 6-inches in diameter.
8. Side sewers within private property shall meet the requirements of the District Standards detailed herein. Gravity side sewers shall have a minimum slope of 2%. Minimum size for gravity sewer lines will be 4-inches for a single family residence and 6-inches for a multi-family residence up to a 4-plex. See Standard Detail S10 for requirements regarding layout (bends) and cleanouts. Sewer cleanouts shall be installed per WSDOT 7-19.
9. Grout for manholes shall be a non-shrinking cementitious grout, containing no gypsum or calcium sulfate Di-hydrate (CaSO₄2H₂O), conforming to WSDOT 9-20.3(2), such as Rapid Set Cement All or approved equivalent. Grout shall be installed according to manufacturer's instructions. JET SET, BLUELINE, AND QUICKCRETE ARE NOT ALLOWED.
10. All sewer pipe and appurtenances shall be flushed and cleaned prior to being put into service. Debris shall not be allowed into the existing sewer system.



11. The District Engineer shall witness testing. Contractor shall provide the District Engineer 48-hours notice prior to conducting tests or sampling.

12. Pipe shall be tested after backfill by the low-pressure air test method per WSDOT 7-17.3(2)F. PVC pipe shall have a mandrel passed through it to check for any deflections in the pipe per WSDOT 7-17.3(2)G. All sewers shall be television inspected and video delivered to the District, with all costs borne by Contractor, before acceptance. Connection to the existing system is not permitted until final acceptance.

13. Side sewers on private property shall be cleaned and tested by either a low pressure air test or exfiltration water test at the option of the Contractor, as per WSDOT 7-17.3(2)A. Water testing shall follow WSDOT 7-17.3(2)B. As stated therein, leakage shall be no more than 0.28 gph per inch diameter per 100 feet of sewer, with a hydrostatic head of 6 feet above the crown at the upper end of the test section, or above the natural ground water table at the time of test, whichever is higher. The length of pipe tested shall be limited so that the pressure at the lower end of the Section tested does not exceed 16 feet of head above the invert.

Where the test head is other than 6 feet, the maximum leakage shall not exceed the amount determined from the following equation:

$$\text{Maximum leakage (in gallons per hour)} = 0.28 \times (\sqrt{H}/\sqrt{6}) \times D \times (L/100)$$

Where:

D = diameter (in.)

L = length of pipe (ft.)

H = test head (ft.)

Air testing may be done in lieu of a water test. An air test is acceptable when air is slowly supplied to the plugged pipe section until the internal air pressure reaches 4 psi and maintains for 5 minutes with no pressure loss.

14. Downspouts, foundation/crawl space sump pumps, yard drains, or any outside drains shall not be connected to sanitary sewer mains or services.

15. Contractor shall prepare Record Drawings of all new sanitary sewer main/lateral construction in accordance with Lake Whatcom Water and Sewer District Design Standards Section 1.2.1 (Record Drawings) and Standard Detail G-6.



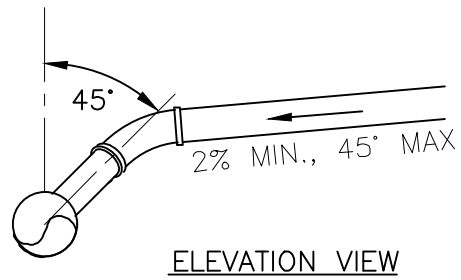
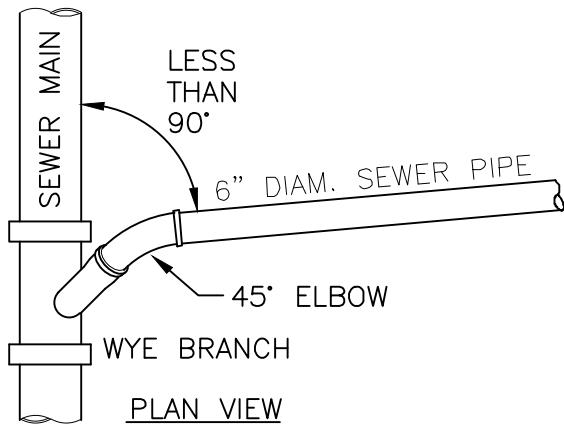

SERVICE LATERAL INSTALLED WITH NEW MAINS

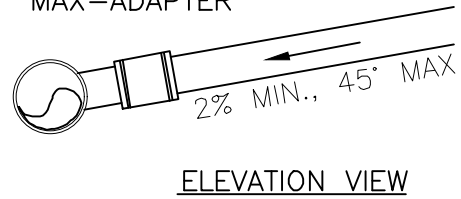
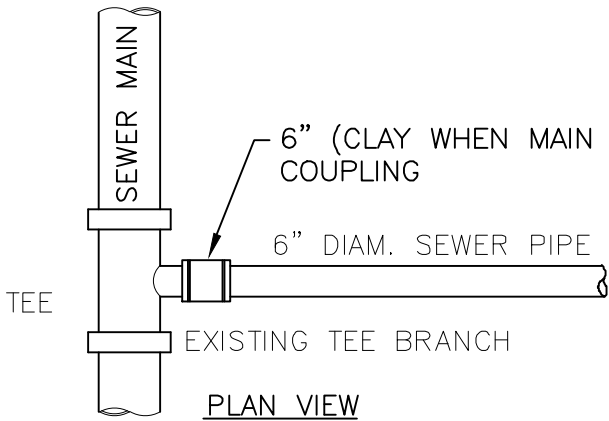

CONNECTION TO EXISTING TEE

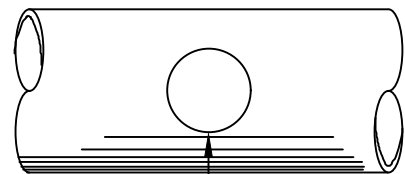
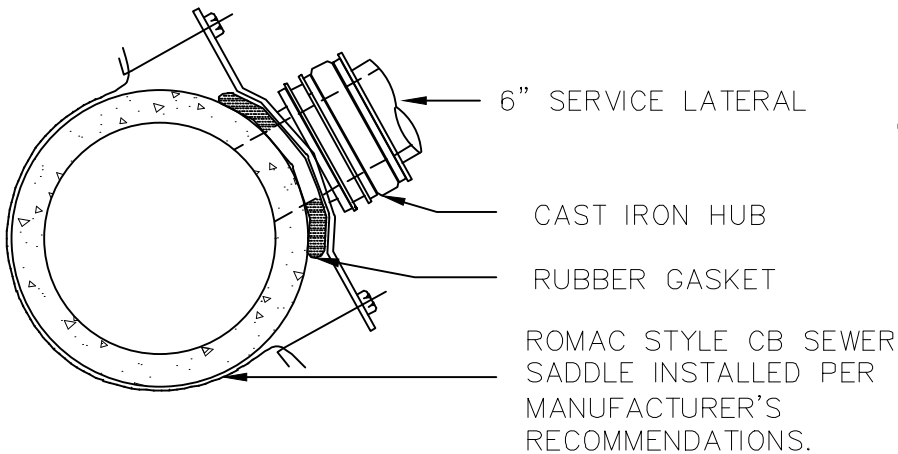

ONLY WITH DISTRICT APPROVAL, MAX 6.4" ϕ BORE HOLE FOR ROMAC STYLE CB SADDLE TAPPING SANITARY SEWER MAIN

NOTES;

1. Install wye fitting with gaskets for new sewer installations
2. Pipe bedding shall Gravel Backfill for Pipe Zone Bedding per WSDOT 9-03.12(3).
3. Minimum cover to finish grade is 30".
4. Core drill hole then remove coupon. Do not drop coupon into pipe.

CONNECTION TO EXISTING SEWER (TAP)



SEWER LATERAL CONNECTION TO MAIN

STANDARD DETAIL

S8

2/23/2022

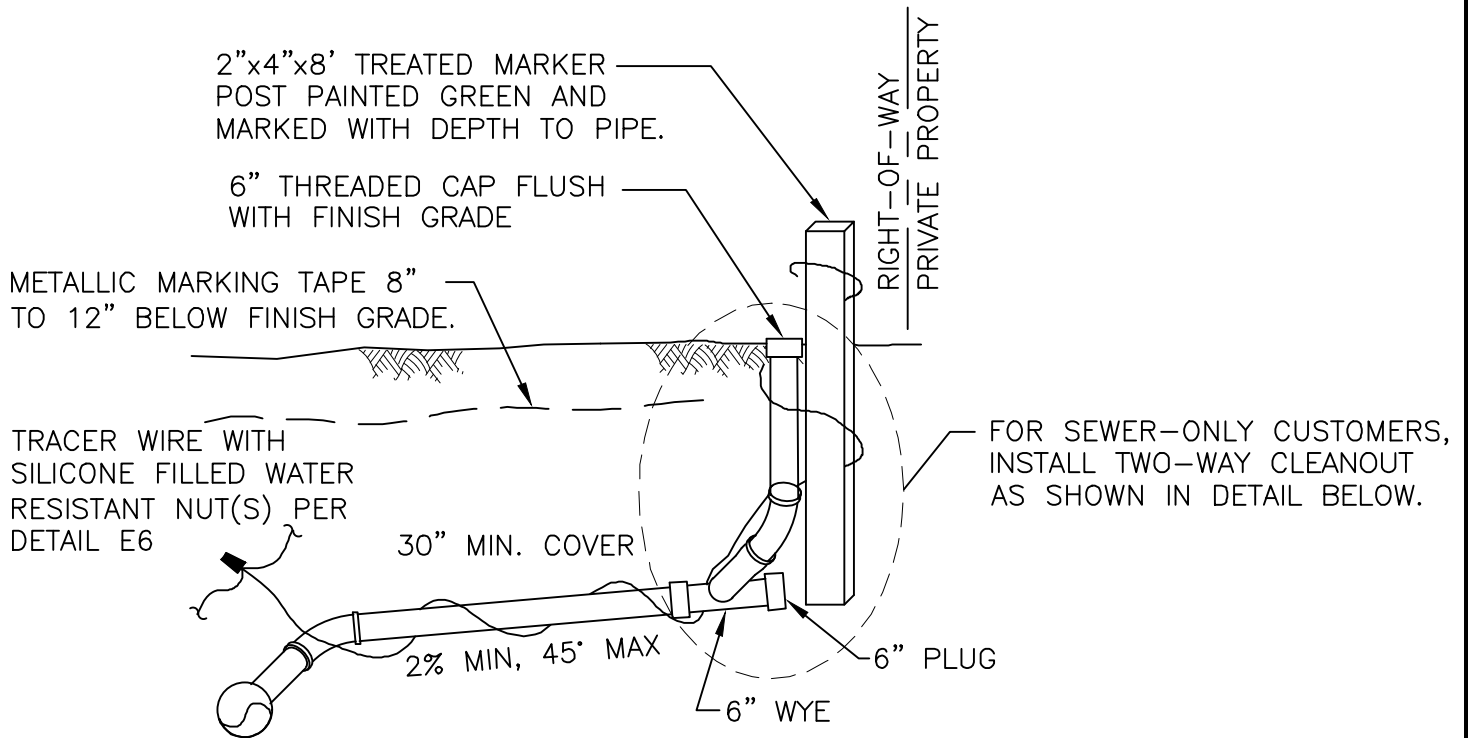

TYPICAL SINGLE SEWER LATERAL & CLEANOUT

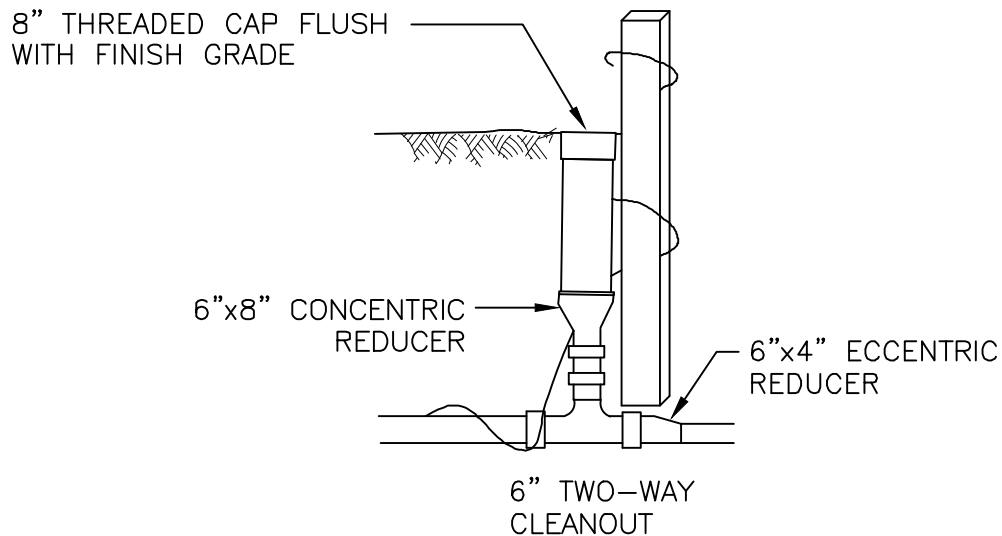

CLEANOUT FOR SEWER-ONLY CUSTOMERS.



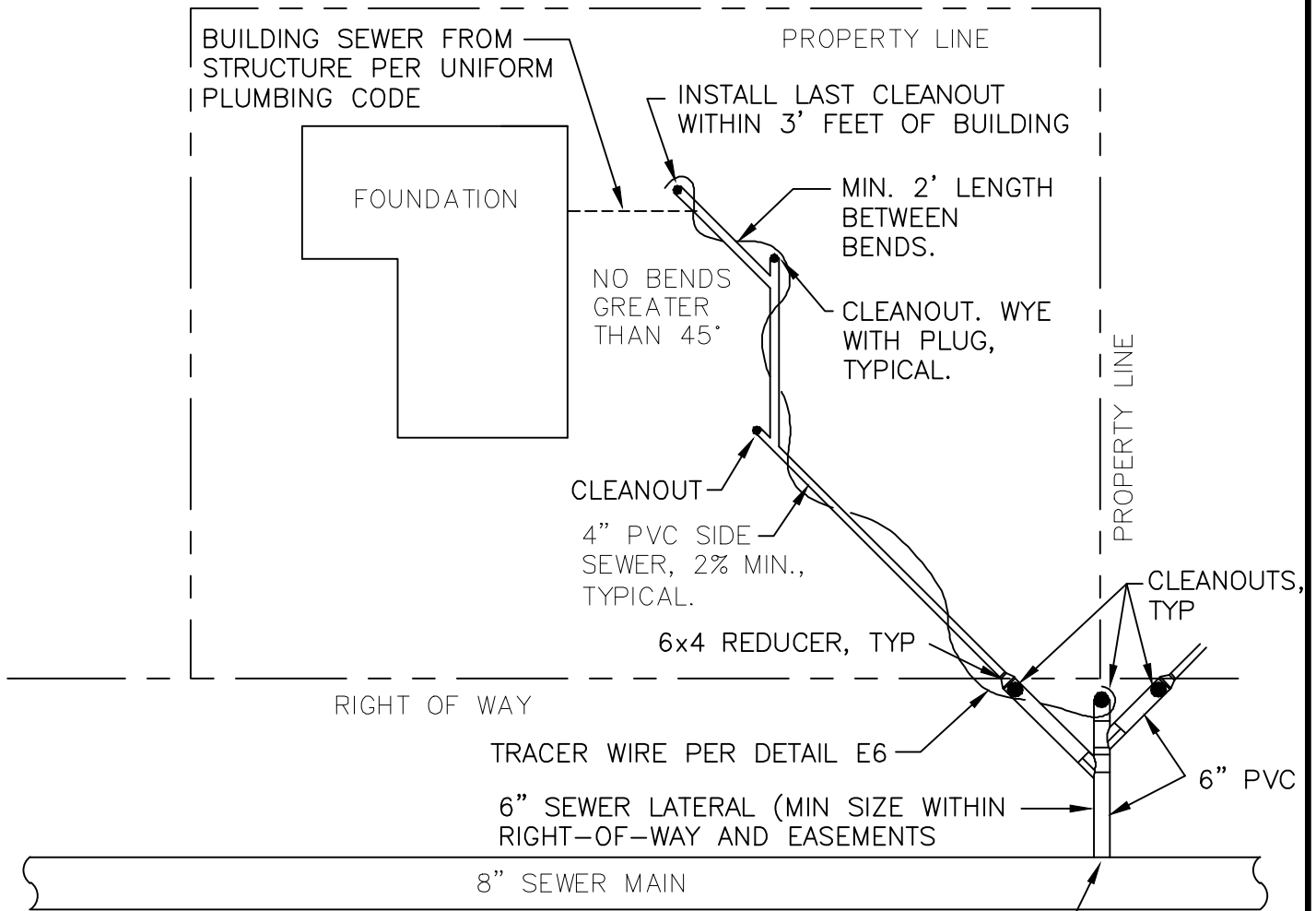

DISTRICT MUST AUTHORIZE ALL CONNECTIONS TO MAINS.
 CONNECTIONS TO MAIN SHALL BE TO EXISTING LATERALS OR TEES.
 ONLY IN SPECIAL CASES SHALL A NEW MAIN TAP BE AUTHORIZED.

Notes:

1. All pipe from main to cleanout at foundation shall be PVC ASTM D3034 SDR 35, joints shall conform to ASTM D3212 using elastomeric gaskets conforming to ASTM F477. Fittings shall be injection molded, factory welded, or factory solvent cemented.
2. Minimum 18" of cover from property line to building.
3. Down spouts, sump pumps, outside drains and storm drainage shall not be connected to the sewer line.
4. Bends greater than 45° will not be accepted.
5. Minimum size for sewer lines will be 4" for single family residence and 6" for multi-family residence up to a 4 plex.
6. Cleanouts on service lines shall be installed at every change in horizontal alignment in excess of 22 1/2 degrees.
7. Cleanouts shall be installed at intervals not to exceed 100 feet.
8. Cleanouts shall be installed for each aggregate horizontal change in direction exceeding 135 degrees.
9. A cleanout shall be installed within 3' of the building.
10. Transitions of different material type shall be with a MAXADAPTER coupling.
11. Side sewers passing under existing or future retaining walls must be installed within a District approved casing pipe.
12. Contractor shall prepare Record Drawings, per Sheet S-2.



GRAVITY SIDE SEWER INSTALLATION

STANDARD DETAIL

S10

2/23/2022

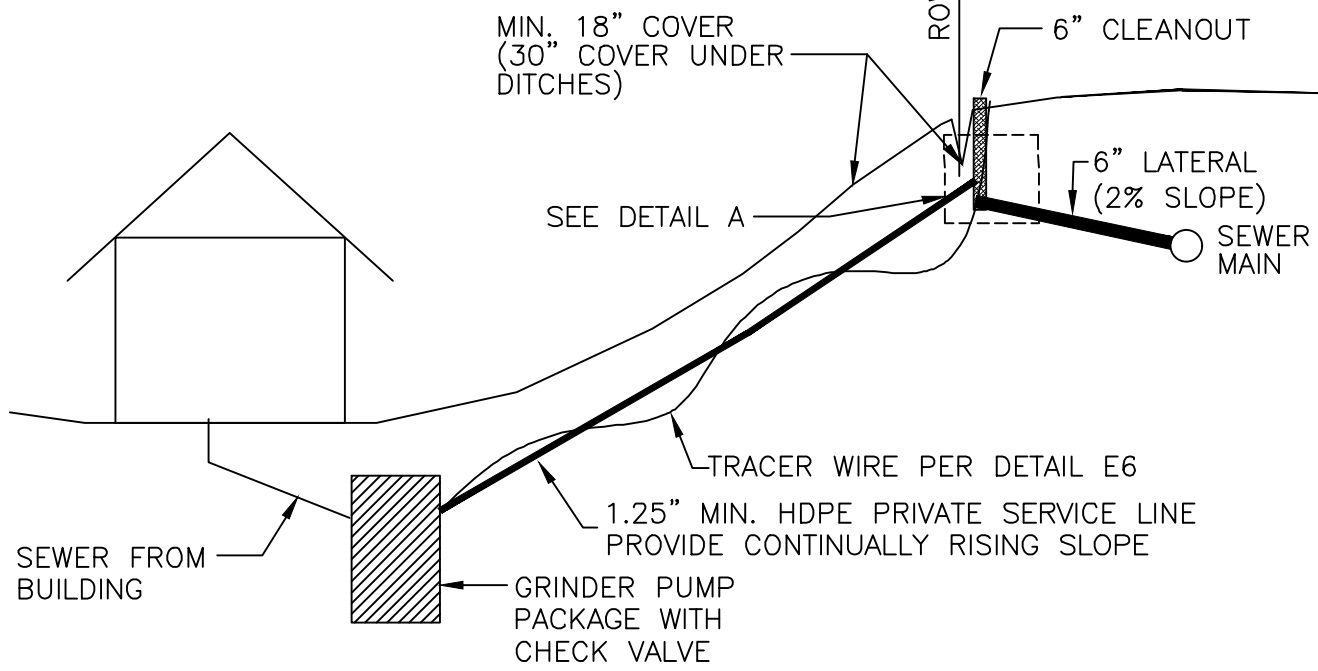
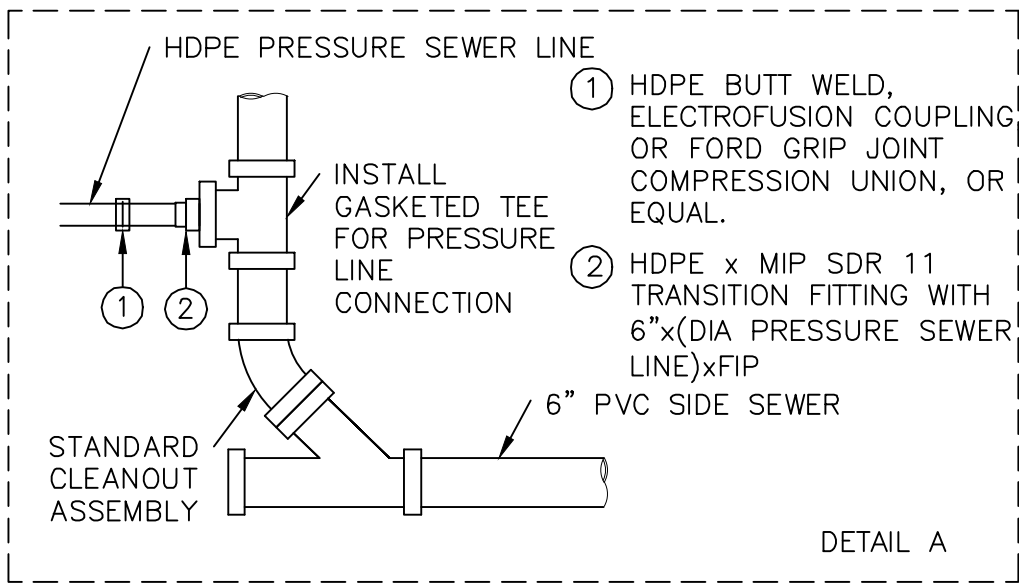

SEE DEPT. OF ECOLOGY (DOE) CRITERIA FOR SEWAGE WORKS DESIGN, SECTIONS C1-10.1 & C1-10.2 FOR GRINDER PUMP DESIGN & COMPONENT INFORMATION

- NOTES:
1. Pressure sewer service pipe shall be PE 3408 HDPE conforming to the requirements of ASTM D-3350. Piping shall be SDR11, IPS (OD), pressure rated at 160 PSI, conforming to the requirements of AWWA C901 and ASTM F714. Fittings shall be electro-fusion welded socket joints. or Ford Grip Joints or equal.
 2. Grinder pump package shall consist of at least a grinder pump, basin, cover, check valve, controls, and interior and exterior visual and audible alarms (with battery backup for high level alarm), provided by Environment-One (E-One, D-Series Package Grinder Pump System) or approved equal.



GRINDER PUMP SERVICE TO GRAVITY MAIN INSTALLATION

STANDARD DETAIL

S11

2/23/2022

INSTALL SADDLE, 2" CORP, VALVE, AND 2" HDPE SERVICE LINE TO PROPERTY LINE. SEE DETAIL S15.

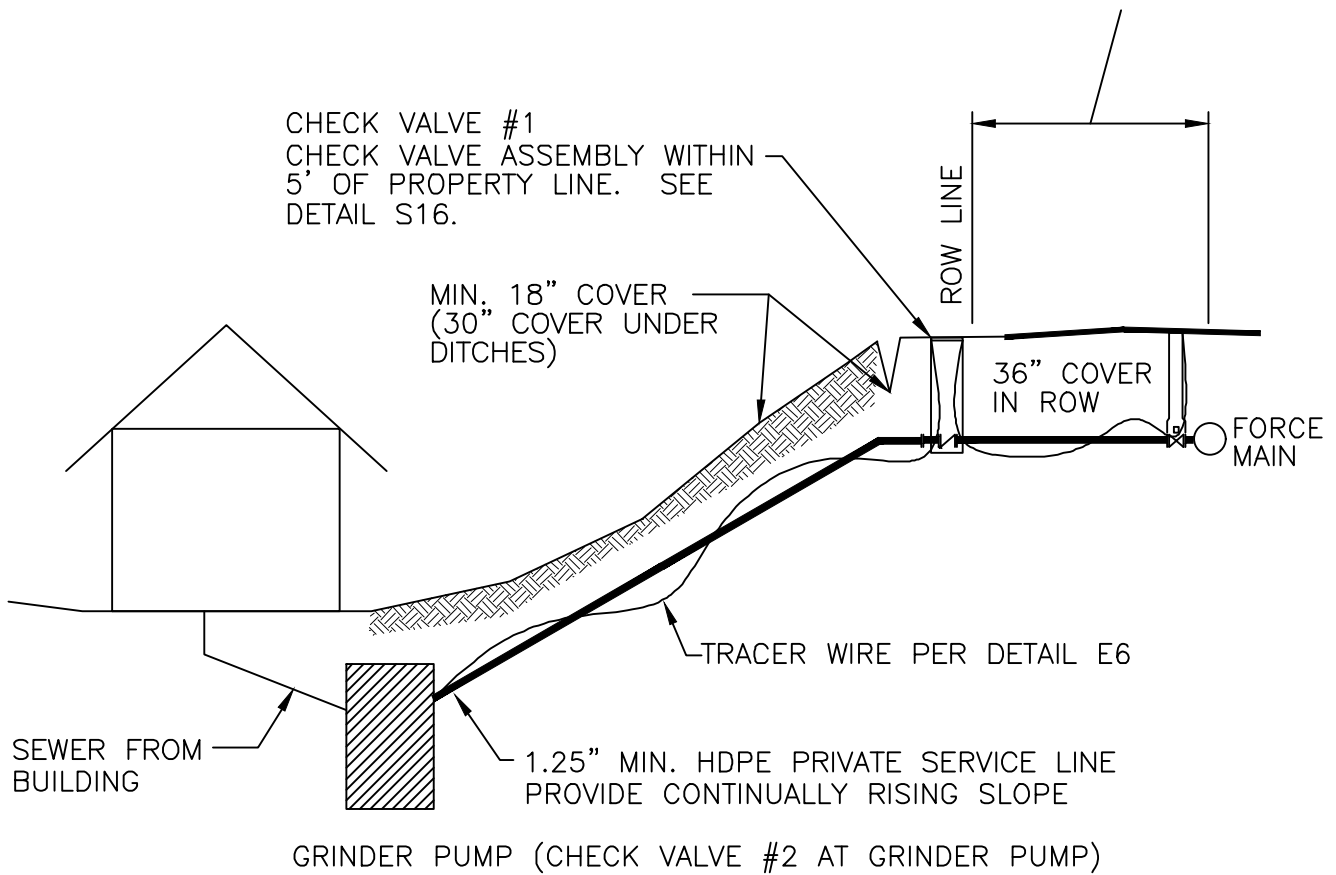

SEE DOE'S CRITERIA FOR SEWAGE WORKS DESIGN, SECTIONS C1-10.1 & C1-10.2 FOR GRINDER PUMP DESIGN & COMPONENT INFORMATION

NOTES:

1. Pressure sewer service pipe shall be PE 3408 HDPE conforming to the requirements of ASTM D-3350. Piping shall be SDR11, IPS (OD), pressure rated at 160 PSI, conforming to the requirements of AWWA C901 and ASTM F714. Fittings shall be electro-fusion welded socket joints, or Ford Grip Joints or equal.
2. Two check valves are required between the pump station and the force main. One check valve shall be installed within 5' of the right-of-way in the check valve vault. The second valve shall be installed at the grinder pump.
3. Grinder pump package shall consist of at least a grinder pump, basin, cover, check valve, controls, and interior and exterior visual and audible alarms (with battery backup for high level alarm), provided by Environment-One (E-One, D-Series Package Grinder Pump System) or approved equal.



GRINDER PUMP SERVICE TO FORCE MAIN INSTALLATION

STANDARD DETAIL

S12

2/23/2022

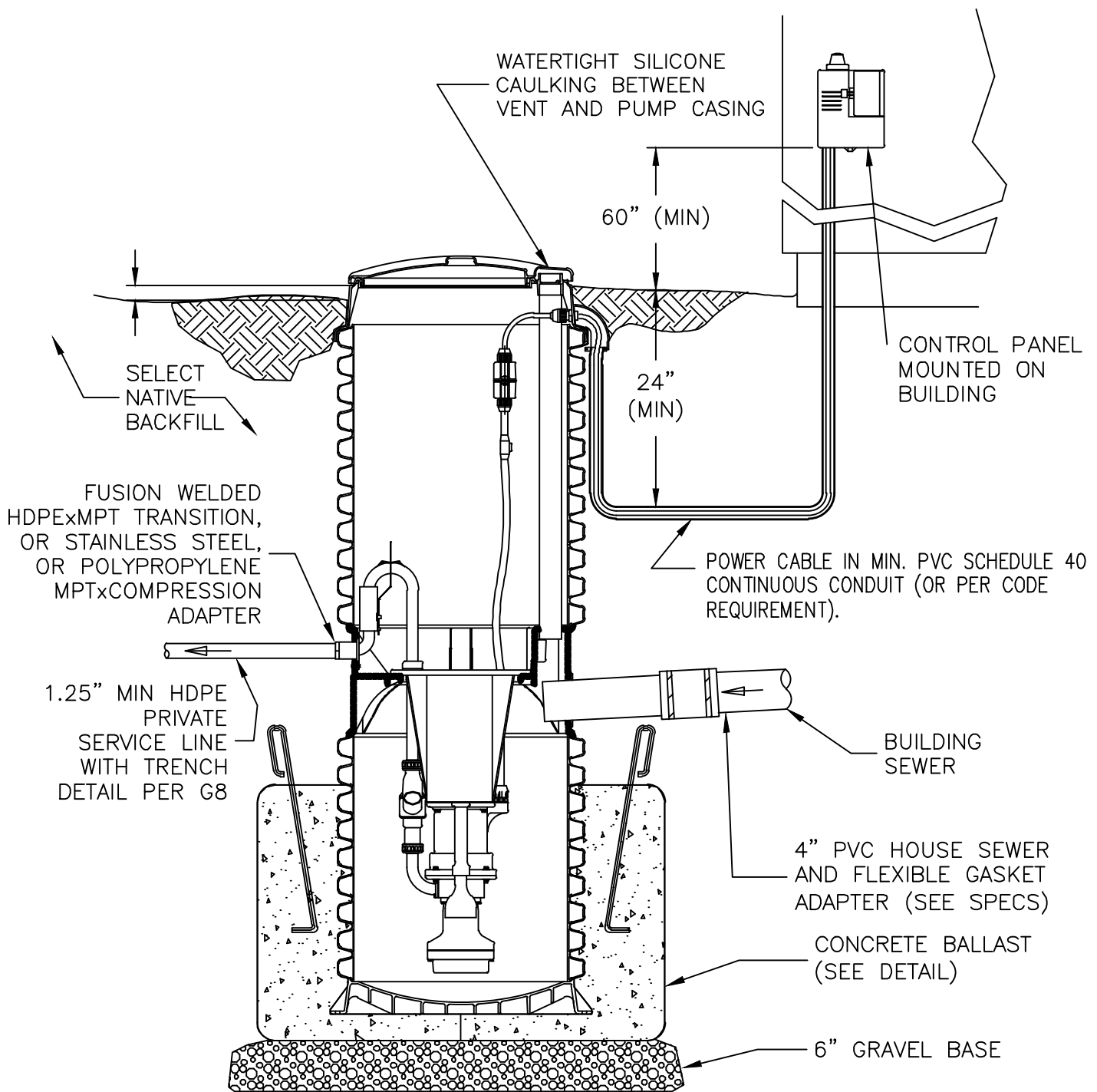

NOTES:

1. Install E/One tank assembly and panel per manufacturer's installation manual and follow requirements for manufacturer's warranty.
2. All fittings shall be Type 316 stainless steel compression fittings, unless specifically noted otherwise.
3. Alarm panel and electrical inspected by others.



TYPICAL E/ONE GRINDER PUMP INSTALLATION

STANDARD DETAIL

S13

2/23/2022

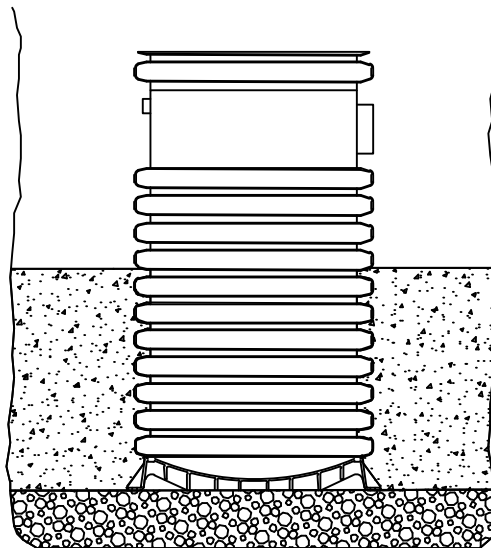

POURED IN PLACE

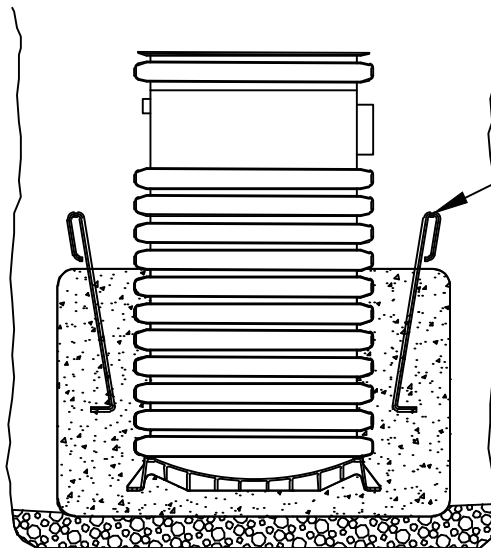

LIFTING EYES,
CONTRACTOR TO
SIZE AS REQUIRED

PRECAST

NOTES

1. PER E/ONE, THE FOLLOWING QUANTITIES OF CONCRETE ARE NECESSARY TO ANCHOR THE TANKS (VERIFY ALL MODEL QUANTITIES WITH MANUFACTURER):
2. ENVIRONMENT ONE MODEL NO. 2010 REQUIRES 370 lbs. (2.5 CU.FT.) PER FOOT OF TOTAL STATION HEIGHT.
3. ENVIRONMENT ONE MODEL NO. 2012 REQUIRES 400 lbs. (2.7 CU.FT.) PLUS 370 lbs. FOR EACH FOOT OF TOTAL STATION HEIGHT.



GRINDER PUMP INSTALLATION
CONCRETE BALLAST

STANDARD DETAIL

S14

3/11/2020

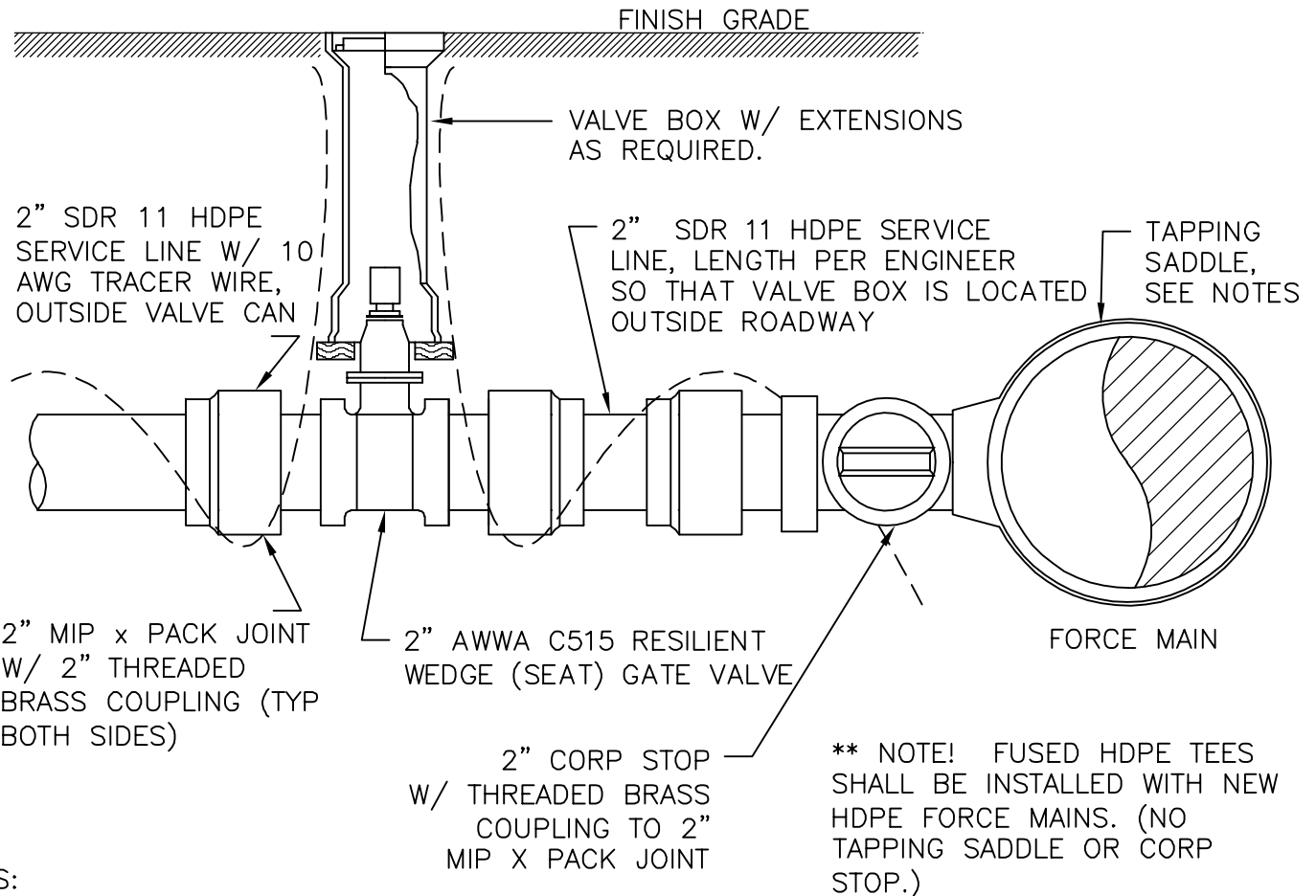

NOTES:

1. HDPE Service Saddles. Saddles for use on SDR 17 HDPE mains shall be epoxy or nylon coated ductile iron tapping saddles with a double stainless steel strapping mechanism specifically recommended by the manufacturer for use on HDPE piping. Saddles shall be Romac style 202N-H or approved equal.
2. PVC Service Saddles. Saddles for use on AWWA C900 PVC mains shall have epoxy or nylon coated ductile iron tapping saddles with a double strap stainless steel strapping mechanism. Service saddles shall be Romac style 202N or approved equal.
3. Ductile Iron Service Saddles. Saddles for use on ductile iron mains shall have epoxy or nylon coated ductile iron tapping saddles with stainless steel tapping mechanism. Service saddles shall be Romac style 101NS or approved equal.
4. Customer Service Shutoff Valves. Shutoff valves shall be resilient wedge type gate valves, in conformance with AWWA C515. Valves shall be suitable for sewage service, class of pipe installed, and be equipped with transition gaskets where needed. Gate valves shall have a non-rising stem and be factory-coated fusion-bonded epoxy coated inside and out meeting AWWA C550. Bolts, nuts and washers shall be ASTM Type 304 stainless-steel. Gate valves shall be M&H AWWA C515, Clow resilient wedge gate valves or approved equal. Gate valve placement shall be outside of travel lanes to a location directed by the Engineer.
5. Valve boxes shall have the word "SEWER" cast into the cover.
6. Fittings. All fittings shall be brass.



CONNECTION TO FORCE MAIN

STANDARD DETAIL

S15

4/26/2023

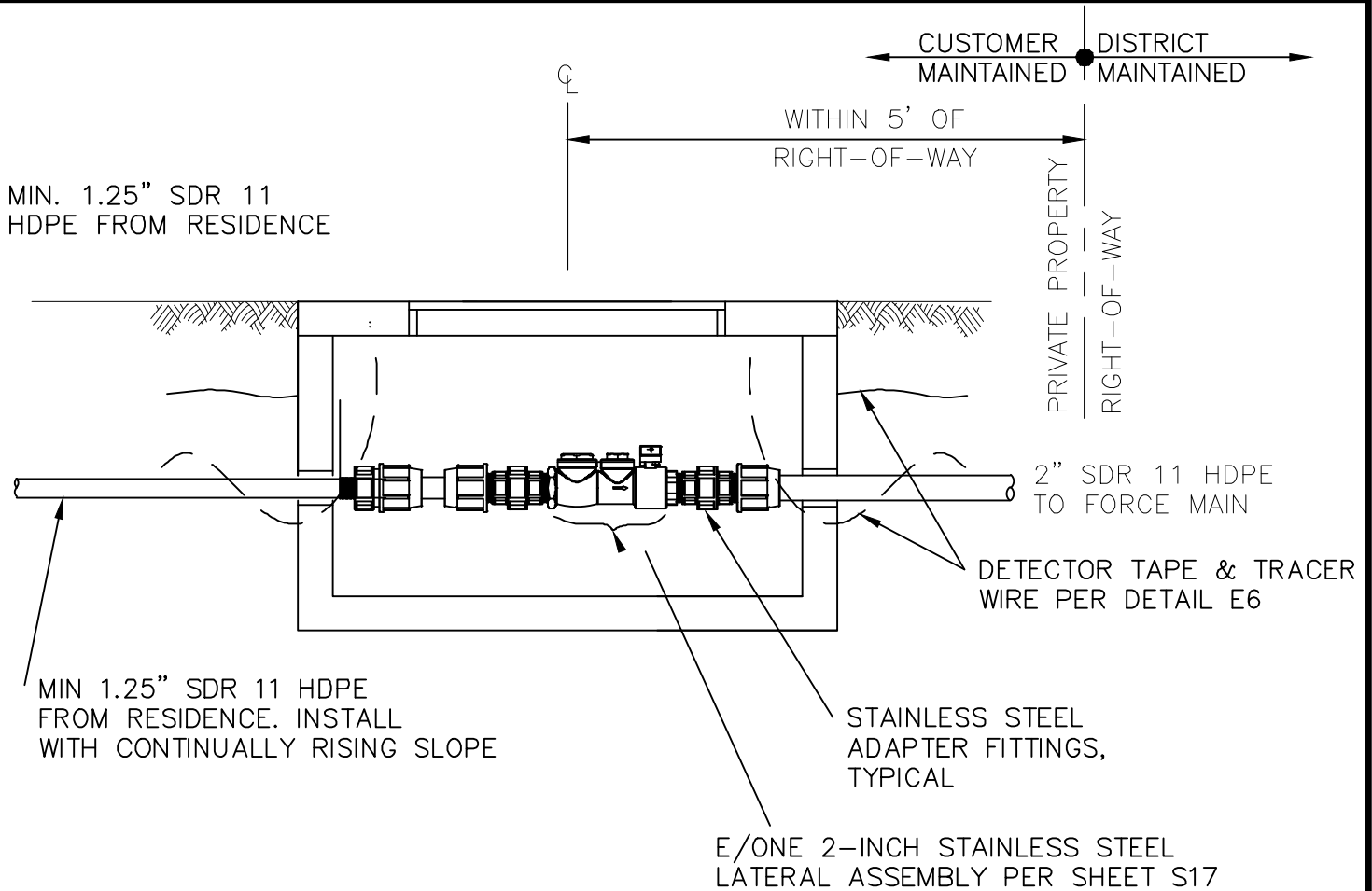

Notes:

1. Vault. Vault shall be a pre-cast concrete hand hole with a minimum 2'-0" by 3'-0" inside diameter and a maximum 4'-0" inside depth. Hand hole and access hatch shall be traffic rated. Access hatch shall be galvanized steel checker plate with pick holes and bolt down holes in plate and shall be designed for H-20 loading when within or adjacent to roadway or driveways. Lid shall be marked "SEWER" with 2" raised letters. Check valve vaults shall be Utility Vault Model 2436 hand hole or approved equal.
2. Air/Vacuum Valve. Where required, in cases where continually rising slope cannot be obtained, an air relief and combination air relief/ vacuum relief valves shall be installed. Air/Vacuum valve shall be as manufactured by Orenco, Apco, Crispin, ARI, or equivalent for sewer service. All valves shall be on private property and be fully accessible to enable customer's operation, maintenance and repair.
3. Fittings and Adapters. Adapter fittings shall be Type 316 stainless steel or polypropylene. Install with appropriate adapters/union fittings for future maintenance and quick disassembly. All fittings, adapters and pipe shall be rated for minimum 235 psi.
4. Install all fittings and adapters per manufacturer's recommendations.
5. Assembly and pipe shall be pressure tested.



FORCE MAIN SERVICE CHECK VALVE

STANDARD DETAIL

S16

2/23/2022

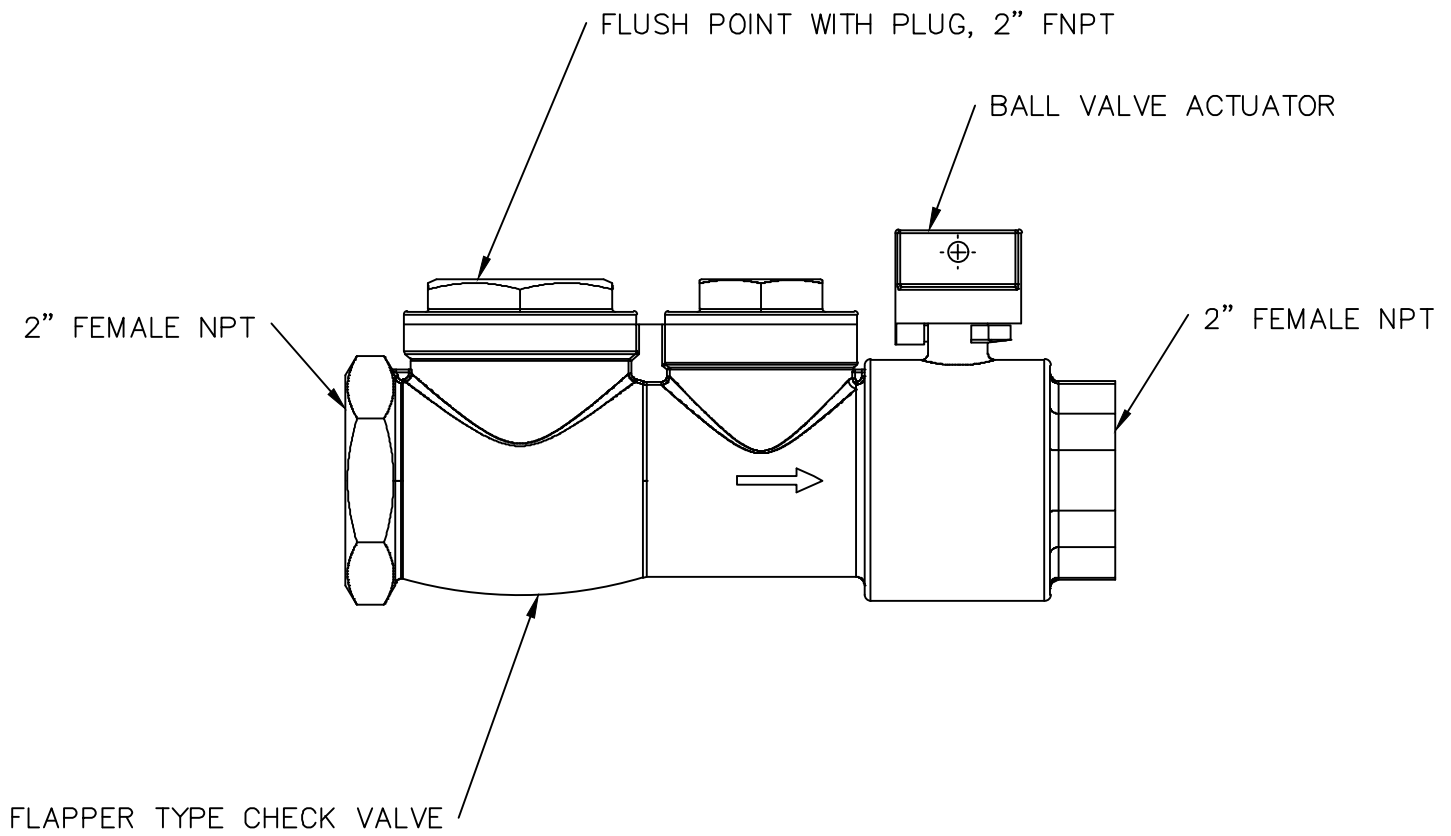

Notes:

1. Assembly shall be Type 316 stainless steel with min 235 psi pressure rating.
2. Assembly is a ball valve curb stop with female pipe threads, valve position stops (open/closed), with flush point and integral check valve. Assembly shall be E/One 2" Lateral Assembly NC0443P01 or approved equal.



E/ONE 2" LATERAL ASSEMBLY

STANDARD DETAIL

S17

3/11/2020

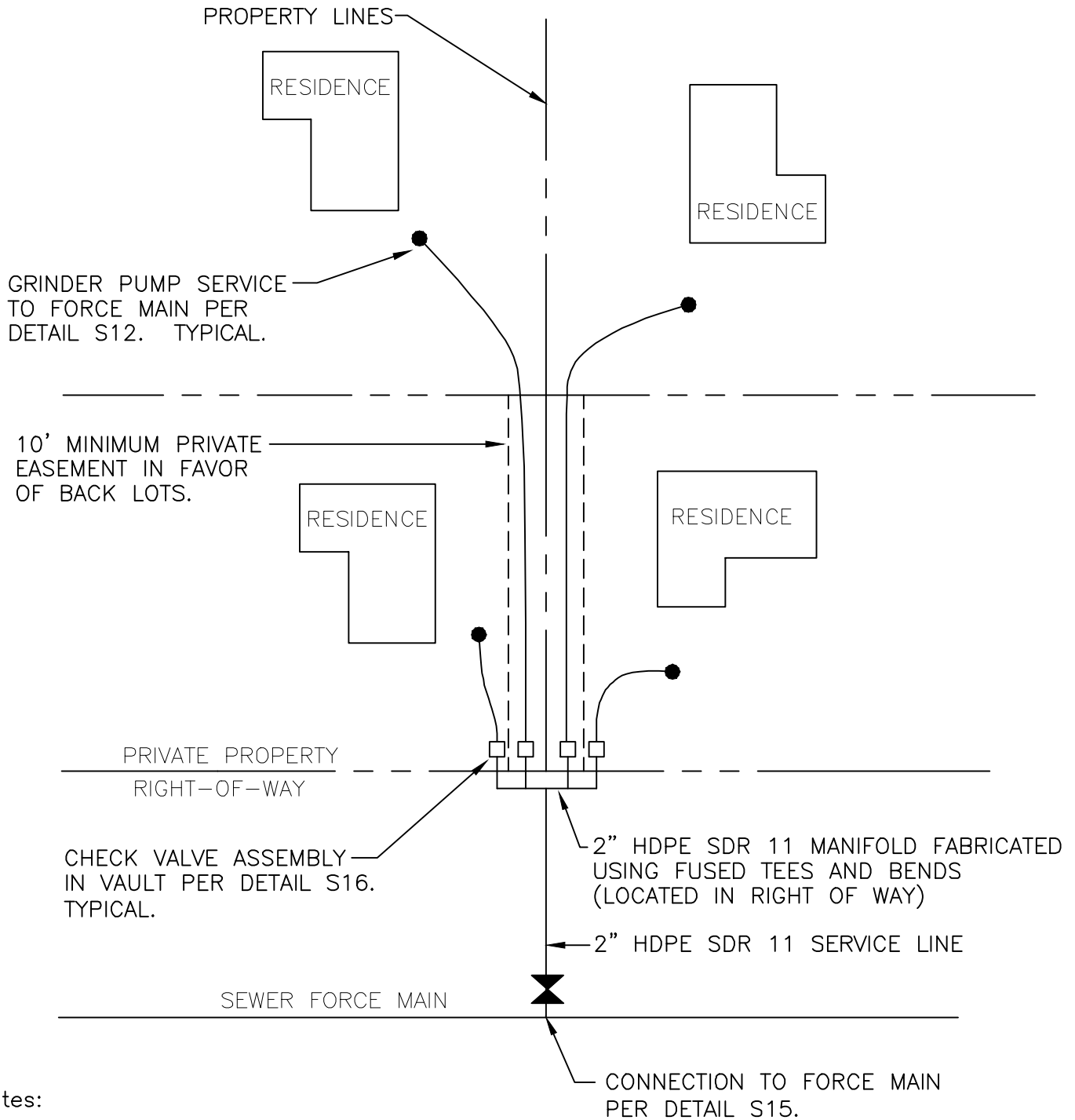

Notes:

1. If approved by the District Engineer, a single 2" service tap may be shared with multiple residences. District will review requests for shared taps on a case by case basis. Property owners desiring to install a shared tap, shall individually but at the same time, submit a sewer permit application with the grinder pump check list for review by the District.
2. Manifold must be fabricated using fused HDPE tees and bends by a contractor certified by a HDPE pipe or fusion machine manufacturer.



SHARED FORCE MAIN SERVICE TAP

STANDARD DETAIL

S18

2/23/2022

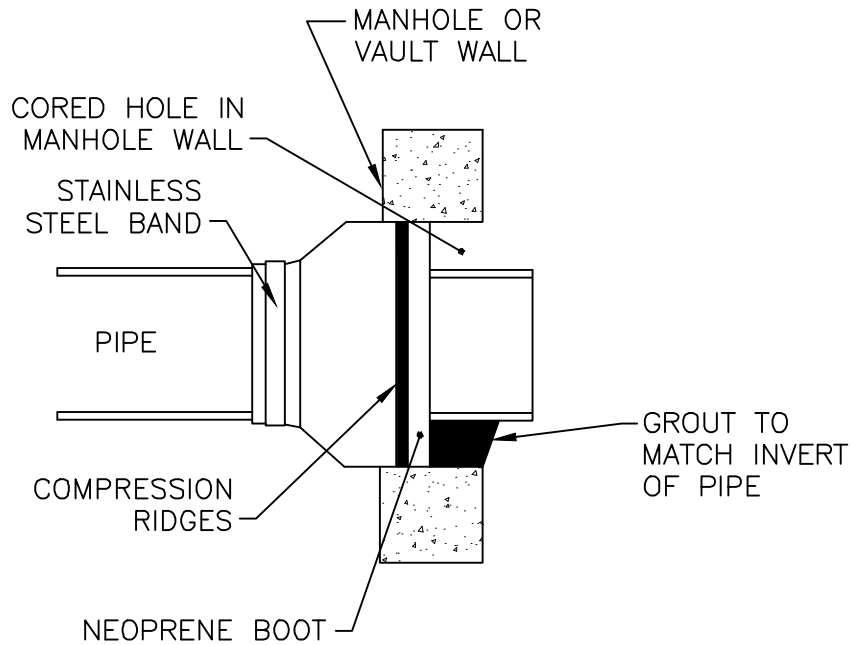

FLEXIBLE SEAL ADAPTER

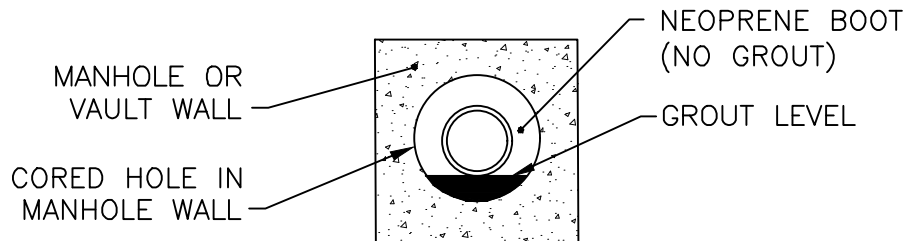

GROUT DETAIL

NOTES:

1. ALL MANHOLE CONNECTIONS SHALL BE 100% WATERTIGHT.
2. ALL PIPE SHALL EXTEND 2" INTO MANHOLE.
3. NEOPRENE BOOT ON THE FLEXIBLE SEAL ADAPTER SHALL BE A MINIMUM OF $\frac{3}{8}$ " THICK PER ASTM C-443, AND SHALL BE HELD IN PLACE WITH AN INTERNAL EXPANDING STAINLESS STEEL BAND SUCH AS "KOR-N-SEAL" OR APPROVED EQUAL.
4. DEFLECTION AT THE ADAPTER MUST NOT EXCEED MANUFACTURER'S RECOMMENDATION. IF SLOPE OF PIPE AT PENETRATION EXCEEDS RECOMMENDED DEFLECTION, CAST OR CORE HOLE AT AN ANGLE SUCH THAT DEFLECTION DOES NOT EXCEED MANUFACTURER'S RECOMMENDATION.



ELECTRICAL, TELECOMMUNICATION AND AUTOMATIC CONTROL NOTES

1. Provide all electrical work and appurtenances in accordance with the latest edition of the National Electric Code (NEC), National Electric Safety Code, Washington State Electrical Code, and local regulations and ordinances.
2. All electrical products shall bear a label from a certified testing laboratory recognized by the State of Washington. Recognized labels in the State of Washington are UL, ETL and CSA-US.
3. The contractor shall coordinate and provide all permits, licenses, approvals and inspections by the authority having jurisdiction, and other arrangements for the work on the project. All fees shall be paid by the Contractor.
4. Test Reports shall be submitted to the Engineer prior to acceptance.
5. Test all circuits for continuity, freedom from ground and proper operation during progress of work.
6. Conduct final testing in the presence of the District Engineer.



ELECTRICAL, TELECOMMUNICATION AND
AUTOMATIC CONTROL NOTES

STANDARD DETAIL

E1

3/11/2020

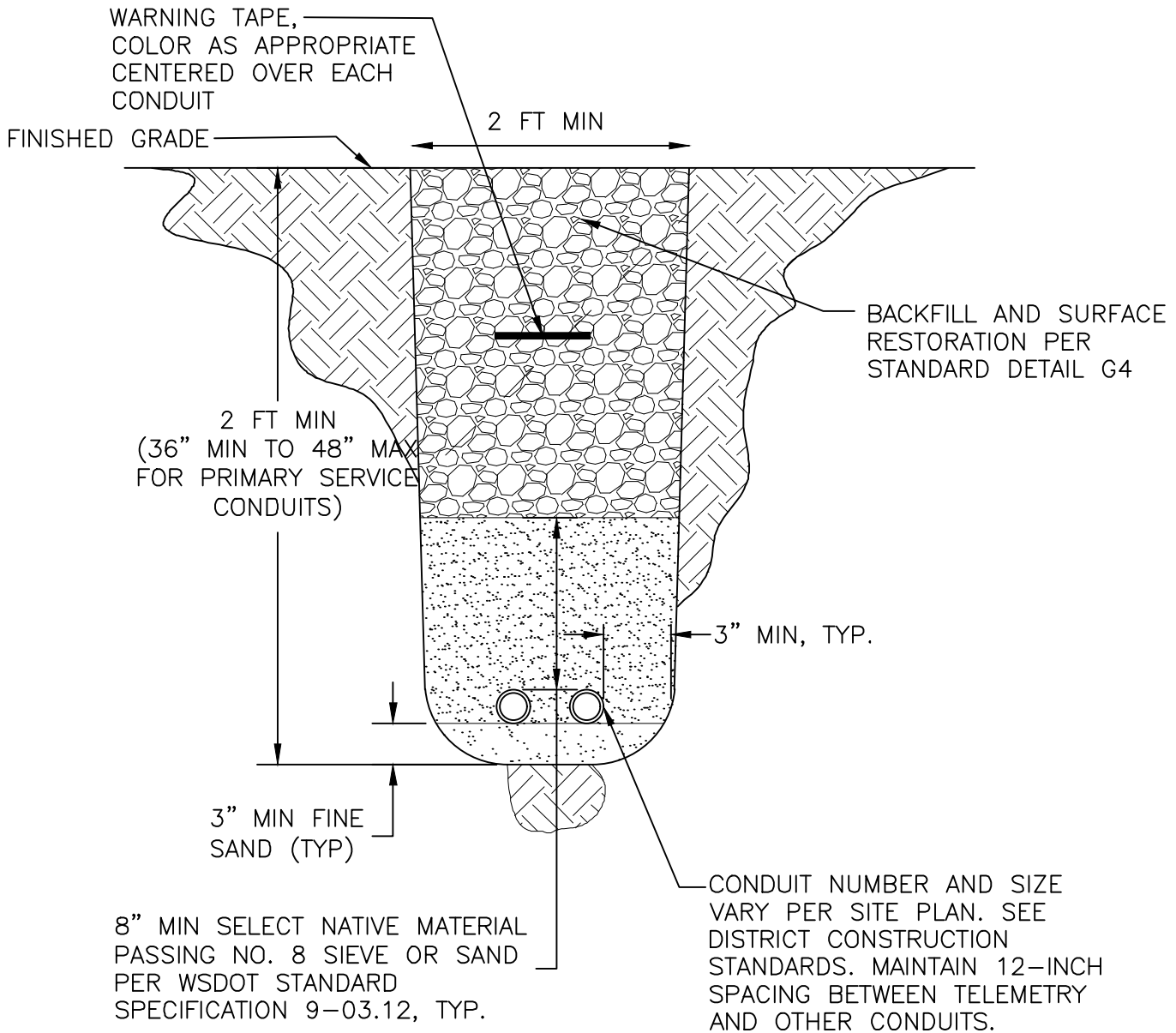

TYPICAL ELECTRICAL / TELECOMMUNICATION /
AUTOMATIC CONTROL TRENCH

STANDARD DETAIL

E2

3/11/2020

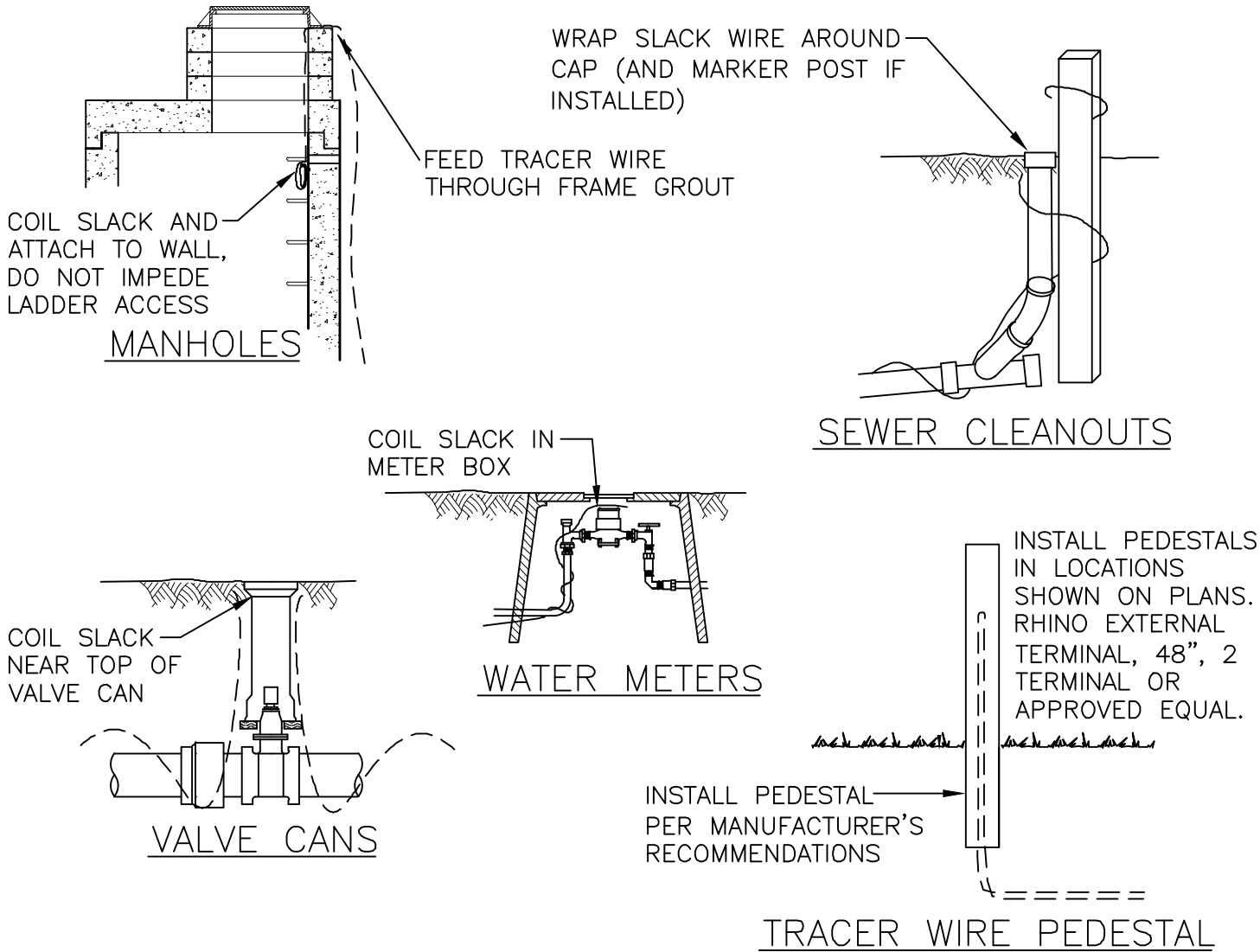

NOTES:

1. Tracer wire installation is required on all District owned pipe and communication lines. Tracer wire is also required on private side sewers and water service lines.
2. Tracer wire shall be 10 AWG insulated copper wire rated for direct burial in wet locations. Use green insulation for sewer, blue insulation for water, and orange insulation for fiber/communication related utilities.
3. Install tracer wire in continuous lengths (no splices) between surface access points. Any direct bury splices shall be approved and inspected by the District Engineer prior to cover. Splices shall be made with silicone filled wire nuts rated for direct burial in wet locations such as "Ideal Underground Wire Connectors", "Ideal Mudbug Connectors," "Copperhead Snakebite Connectors," or "3M DBR Direct Bury Splice Kit."
4. Tape tracer wire to pipe at 10-foot intervals.
5. Provide at least 2-feet of coiled tracer wire slack at surface access points.
6. Wrap tracker wire on the outside of valve cans, tape secure.



TRACER WIRE

STANDARD DETAIL

E6

3/11/2020